



ORIS

Committed to the forefront of SPROCKET manufacturing

Tooth Profiles of Sprockets

Tooth Space Profile

For Roller Chains DIN8187-ISO/R606

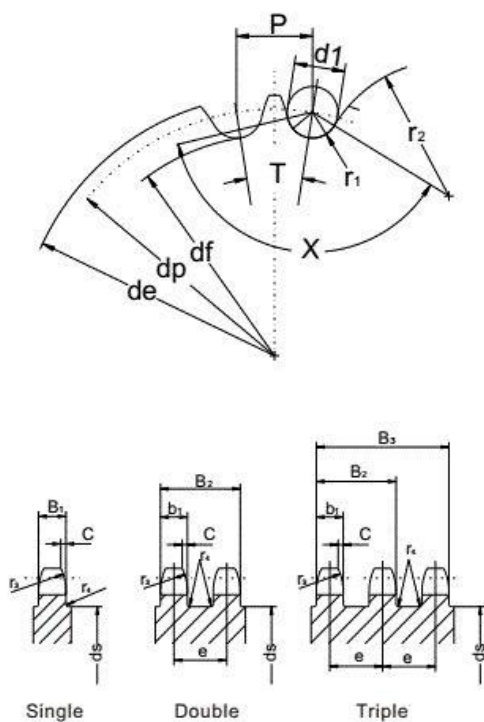

Single Double Triple
Dimensions in mm

Permissible tolerance

Root diameter	h11
Tooth width	h14
Radial runout between bore and root diameter: 0.0008df + 0.08 or 0.15 (depending on which value is larger) but not to exceed 0.76mm	
Axial runout between bore and gear rim face: 0.0009df + 0.08, not to exceed 1.14mm	

P=Pitch
Z=Teeth
d1=Roller Diameter

Formulae

Pitch Diameter

$$dp = \frac{P}{\sin(180^\circ/Z)}$$

Root Diameter

$$df = da - d1$$

Tip Diameter

$$de_{max.} = dp + 1.25P - d1$$

$$de_{min.} = dp + (1 - 1.6/Z)P - d1$$

Groove Diameter

$$ds = P \cdot \cot(180^\circ/Z) - 1.05g - 2r4 - 1$$

(g = max. height of link plate)

Roller bed radius

$$r_{1max.} = 0.505d1 + 0.069\sqrt{d1}$$

$$r_{1min.} = 0.505d1$$

Roller bed angle

$$\chi_{max.} = 140^\circ - 90^\circ/Z$$

$$\chi_{min.} = 120^\circ - 90^\circ/Z$$

Tooth flank radius

$$r_{2max.} = 0.008d1 (Z + 180)$$

$$r_{2min.} = 0.12d1 (P - d1)$$

Tooth width

	$P \leq 12.7$	$P \geq 12.7$
Single sprocket B ₁	0.93b	0.95b
Double and triple sprocket b ₁	0.91b	0.93b
Quadruple sprocket and above b ₁	0.88b	0.93b

Single sprocket B₁ 0.93b 0.95b

Double and triple sprocket b₁ 0.91b 0.93b

Quadruple sprocket and above b₁ 0.88b 0.93b

(b = internal width of chain)

Tooth Chamfer

$$C = 0.1b_{is} / \text{to } 0.15P$$

Tooth Chamfer Radius

$$r_3 \geq 2P$$



Sprockets for Roller Chains DIN8187-ISO/R606

5x2.5 mm 03B-1

CHAIN 配套链条尺寸: Pitch 节距: 5 mm
 Internal width 内链板宽度: 2.5 mm
 Roller dia. 滚径: 3.2 mm

SPROCKET 链轮尺寸: Tooth radius 齿半径 r: 5 mm
 Radius width 圆弧倒角宽度 C: 0.6 mm
 Tooth width 齿宽 h1: 2.3 mm
 Tooth width 齿宽 L: -
 Tooth width 齿宽 h2: -
 Tooth width 齿宽 h3: -
 Full height 总高 H:-

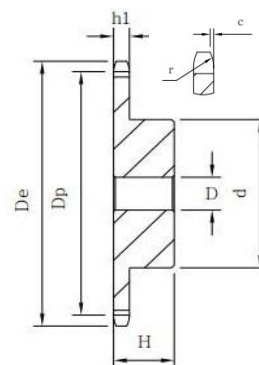

Teeth	齿数	De 外径	Dp 节径	Simplex 单排		
				d 搭径	D 内孔	H 总高
8		15.2	13.06	7	4	10
9		16.8	14.62	8	5	10
10		18.3	16.18	9	5	10
11		19.9	17.75	11	6	10
12		21.5	19.32	12	6	10
13		23	20.89	14	6	10
14		24.6	22.47	15	6	10
15		26.2	24.04	16	6	10
16		27.8	25.63	18	8	13
17		29.4	27.2	18	8	13
18		30.9	28.79	18	8	13
19		32.5	30.38	18	8	13
20		34.1	31.96	18	8	13
21		35.7	33.54	20	8	13
22		37.3	35.13	20	8	13
23		38.9	36.72	20	8	13
24		40.5	38.3	20	8	13
25		42	39.89	20	8	13
26		43.6	41.48	25	8	15
27		45.2	43.07	25	8	15
28		46.8	44.65	25	8	15
29		48.4	46.25	25	8	15
30		50	47.83	25	8	15
31		51.6	49.42	30	8	15
32		53.2	51.01	30	8	15
33		54.8	52.6	30	8	15
34		56.3	54.19	30	8	15
35		57.9	55.78	30	8	15
36		59.5	57.37	30	8	15
37		61.1	58.96	30	8	15
38		62.7	60.54	30	8	15
39		64.3	62.13	30	8	15
40		65.9	63.73	30	8	15



Sprockets for Roller Chains DIN8187-ISO/R606

5x2.5 mm 03A-1

CHAIN 配套链条尺寸: Pitch 节距: 5 mm
 Internal width 内链板宽度: 2.5 mm
 Roller dia. 滚径: 3.2 mm

SPROCKET 链轮尺寸: Tooth radius 齿半径 r: 5 mm
 Radius width 圆弧倒角宽度 C: 0.6 mm
 Tooth width 齿宽 h1: 2.3 mm
 Tooth width 齿宽 L: -
 Tooth width 齿宽 h2: -
 Tooth width 齿宽 h3: -
 Full height 总高 H:-

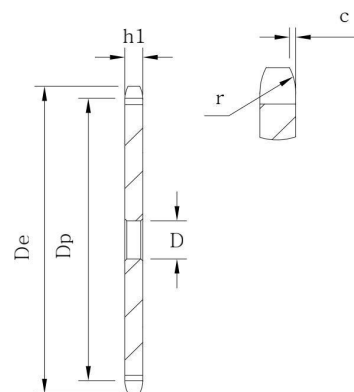

Teeth	齿数	De 外径	Dp 节径	Simplex 单排		
				D 内孔		
8		15.2	13.06	4		
9		16.8	14.62	4		
10		18.3	16.18	4		
11		19.9	17.75	5		
12		21.5	19.32	5		
13		23	20.89	5		
14		24.6	22.47	5		
15		26.2	24.04	5		
16		27.8	25.63	6		
17		29.4	27.2	6		
18		30.9	28.79	6		
19		32.5	30.38	6		
20		34.1	31.96	6		
21		35.7	33.54	8		
22		37.3	35.13	8		
23		38.9	36.72	8		
24		40.5	38.3	8		
25		42	39.89	8		
26		43.6	41.48	8		
27		45.2	43.07	8		
28		46.8	44.65	8		
29		48.4	46.25	8		
30		50	47.83	8		
31		51.6	49.42	8		
32		53.2	51.01	8		
33		54.8	52.6	8		
34		56.3	54.19	8		
35		57.9	55.78	8		
36		59.5	57.37	8		
37		61.1	58.96	8		
38		62.7	60.54	8		
39		64.3	62.13	8		
40		65.9	63.73	8		



Sprockets for Roller Chains DIN8187-ISO/R606

6x2.8 mm 04B-1

CHAIN 配套链条尺寸: Pitch 节距: 6 mm
 Internal width 内链板宽度: 2.8 mm
 Roller dia. 滚径: 5 mm

SPROCKET 链轮尺寸: Tooth radius 齿半径 r: 6 mm
 Radius width 圆弧倒角宽度 C: 0.7 mm
 Tooth width 齿宽 h1: 2.6 mm
 Tooth width 齿宽 L: -
 Tooth width 齿宽 h2: -
 Tooth width 齿宽 h3: -
 Full height 总高 H:-

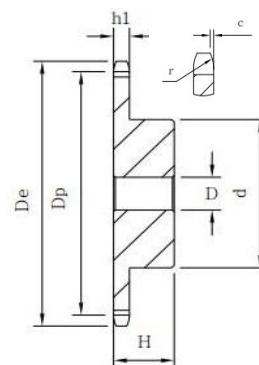

Teeth	齿数	De 外径	Dp 节径	Simplex 单排		
				d 搭径	D 内孔	H 总高
8		18	15.67	9.8	5	10
9		19.9	17.54	11.5	5	10
10		21.7	19.42	13	6	10
11		23.6	21.3	14	6	10
12		25.4	23.18	16	6	10
13		27.3	25.05	18	8	10
14		29.2	26.96	20	8	10
15		31	28.86	20	8	10
16		33	30.76	20	8	13
17		35	32.65	20	8	13
18		36.9	34.55	20	8	13
19		38.8	36.44	20	8	13
20		40.7	38.34	20	8	13
21		42.6	40.25	25	8	13
22		44.5	42.16	25	8	13
23		46.4	44.06	25	8	13
24		48.3	45.96	25	8	13
25		50.2	47.87	25	8	13
26		52.1	49.76	30	8	15
27		54	51.67	30	8	15
28		55.9	53.58	30	8	15
29		57.8	55.5	30	8	15
30		59.8	57.42	30	8	15
31		61.7	59.31	30	8	15
32		63.6	61.21	30	8	15
33		65.5	63.11	30	8	15
34		67.4	65.02	30	8	15
35		69.3	66.93	30	8	15
36		71.2	68.84	30	8	15
37		73.1	70.75	30	8	15
38		75	72.66	30	8	15
39		76.9	74.57	30	8	15
40		78.9	76.47	30	8	15



Sprockets for Roller Chains DIN8187-ISO/R606

6x2.8 mm 04A-1

CHAIN 配套链条尺寸: Pitch 节距: 6 mm
 Internal width 内链板宽度: 2.8mm
 Roller dia. 滚径: 4 mm

SPROCKET 链轮尺寸: Tooth radius 齿半径 r: 6 mm
 Radius width 圆弧倒角宽度 C: 0.7 mm
 Tooth width 齿宽 h1: 2.6 mm
 Tooth width 齿宽 L: -
 Tooth width 齿宽 h2: -
 Tooth width 齿宽 h3: -
 Full height 总高 H:-

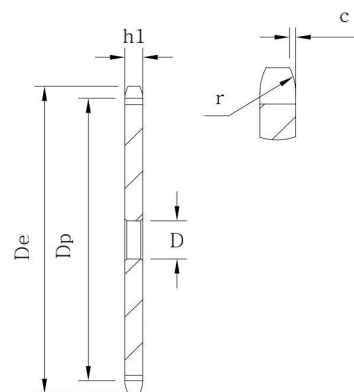

Teeth	齿数	De 外径	Dp 节径	Simplex 单排		
				D 内孔		
8		18	15.67	5		
9		19.9	17.54	5		
10		21.7	19.42	6		
11		23.6	21.3	6		
12		25.4	23.18	6		
13		27.3	25.05	8		
14		29.2	26.96	8		
15		31	28.86	8		
16		33	30.76	8		
17		35	32.65	8		
18		36.9	34.55	8		
19		38.8	36.44	8		
20		40.7	38.34	8		
21		42.6	40.25	8		
22		44.5	42.16	8		
23		46.4	44.06	8		
24		48.3	45.96	8		
25		50.2	47.87	8		
26		52.1	49.76	8		
27		54	51.67	8		
28		55.9	53.58	8		
29		57.8	55.5	8		
30		59.8	57.42	8		
31		61.7	59.31	8		
32		63.6	61.21	8		
33		65.5	63.11	8		
34		67.4	65.02	8		
35		69.3	66.93	8		
36		71.2	68.84	8		
37		73.1	70.75	8		
38		75	72.66	8		
39		76.9	74.57	8		
40		78.9	76.47	8		



Sprockets for Roller Chains DIN8187-ISO/R606

8 x 3 mm 05B-1 -2

CHAIN 配套链条尺寸: Pitch 节距: 8 mm
 Internal width 内链板宽度: 3 mm
 Roller dia. 滚径: 5 mm

SPROCKET 链轮尺寸: Tooth radius 齿半径 r: 8 mm
 Radius width 圆弧倒角宽度 C: 1 r
 Tooth width 齿宽 h1: 2.8 mm
 Tooth width 齿宽 L: 2.7 mm
 Tooth width 齿宽 h2: 8.3 mm
 Tooth width 齿宽 h3: -
 Full height 总高 H:-

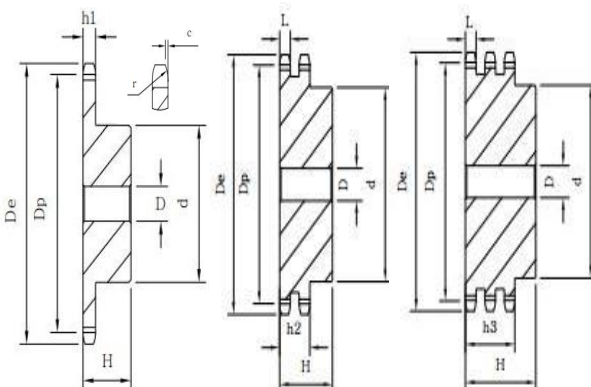

Teeth 齿数	De 外径	Dp 节径	Simplex 单排			Duplex 双排			Triplex 三排		
			d 搭径	D 内孔	H 总高	d 搭径	D 内孔	H 总高	d 搭径	D 内孔	H 总高
8	24	20.9	13	6	12	12	8	18			
9	26.6	23.39	15	6	12	15	8	18			
10	29.2	25.89	17	8	12	17	8	18			
11	31.7	28.39	18	8	13	19	8	18			
12	34.2	30.91	20	8	13	21	8	18			
13	36.7	33.42	23	8	13	24	8	18			
14	39.2	35.95	25	8	13	26	8	18			
15	41.7	38.48	28	8	13	29	8	18			
16	44.3	41.01	30	8	14	32	10	20			
17	46.8	43.53	30	8	14	34	10	20			
18	49.3	46.07	30	8	14	37	10	20			
19	51.9	48.61	30	8	14	39	10	20			
20	54.4	51.14	30	8	14	40	10	20			
21	57	53.68	35	8	14	40	10	20			
22	59.5	56.21	35	8	14	40	10	20			
23	62	58.75	35	8	14	40	10	20			
24	64.6	61.29	35	8	14	40	10	20			
25	67.5	63.83	35	8	14	40	10	20			
26	67.9	66.37	40	10	16	50	12	22			
27	72.2	68.91	40	10	16	50	12	22			
28	74.8	71.45	40	10	16	50	12	22			
29	77.3	73.99	40	10	16	50	12	22			
30	79.8	76.53	40	10	16	50	12	22			
31	82.4	79.08	40	10	16	60	12	22			
32	84.9	81.61	40	10	16	60	12	22			
33	87.5	84.16	40	10	16	60	12	22			
34	90	86.7	40	10	16	60	12	22			
35	92.5	89.25	40	10	16	60	12	22			
36	95	91.79	40	10	16	60	12	22			
37	97.6	94.33	40	10	16	60	12	22			
38	100.2	96.88	40	10	16	60	12	22			
39	102.7	99.42	40	10	16	60	12	22			
40	105.3	101.97	40	10	16	60	12	22			



Sprockets for Roller Chains DIN8187-ISO/R606

8 x 3 mm

05A-1 -2

CHAIN 配套链条尺寸: Pitch 节距: 8 mm
 Internal width 内链板宽度: 3 mm
 Roller dia. 滚径: 5 mm

SPROCKET 链轮尺寸: Tooth radius 齿半径 r: 8 mm
 Radius width 圆弧倒角宽度 C: 1 mm
 Tooth width 齿宽 h1: 2.8 mm
 Tooth width 齿宽 L: 2.7 mm
 Tooth width 齿宽 h2: 8.3 mm
 Tooth width 齿宽 h3: -
 Full height 总高 H:-

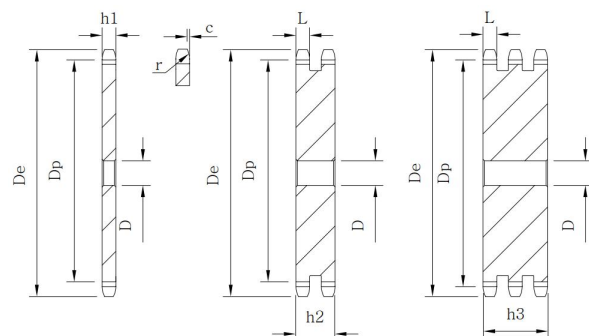

Teeth	齿数	De 外径	Dp 节径	Simplex 单排	Duplex 双排	Triplex 三排
				D 内孔	D 内孔	D 内孔
8		24	20.9	6	8	
9		26.6	23.39	6	8	
10		29.2	25.89	8	8	
11		31.7	28.39	8	8	
12		34.2	30.91	8	8	
13		36.7	33.42	8	8	
14		39.2	35.95	8	8	
15		41.7	38.48	8	8	
16		44.3	41.01	8	10	
17		46.8	43.53	8	10	
18		49.3	46.07	8	10	
19		51.9	48.61	8	10	
20		54.4	51.14	8	10	
21		57	53.68	8	10	
22		59.5	56.21	8	10	
23		62	58.75	8	10	
24		64.6	61.29	8	10	
25		67.5	63.83	8	10	
26		67.9	66.37	10	12	
27		72.2	68.91	10	12	
28		74.8	71.45	10	12	
29		77.3	73.99	10	12	
30		79.8	76.53	10	12	
31		82.4	79.08	10	12	
32		84.9	81.61	10	12	
33		87.5	84.16	10	12	
34		90	86.7	10	12	
35		92.5	89.25	10	12	
36		95	91.79	10	12	
37		97.6	94.33	10	12	
38		100.2	96.88	10	12	
39		102.7	99.42	10	12	
40		105.3	101.97	10	12	



Sprockets for Roller Chains DIN8187-ISO/R606

3/8" x 7/32" mm

06B-1 -2 -3

CHAIN 配套链条尺寸: Pitch 节距: 9.525mm
 Internal width 内链板宽度: 5.72 mm
 Roller dia. 滚径: 6.35 mm

SPROCKET 链轮尺寸: Tooth radius 齿半径 r: 10 mm
 Radius width 圆弧倒角宽度 C: 1 mm
 Tooth width 齿宽 h1: 5.3 mm
 Tooth width 齿宽 L: 5.2 mm
 Tooth width 齿宽 h2: 15.4 mm
 Tooth width 齿宽 h3: 25.6 mm
 Full height 总高 H:-

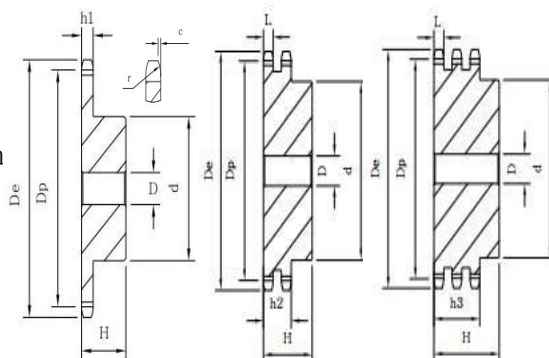

Teeth 齿数	De 外径	Dp 节径	Simplex 单排			Duplex 双排			Triplex 三排		
			d 搭径	D 内孔	H 总高	d 搭径	D 内孔	H 总高	d 搭径	D 内孔	H 总高
8	28	24.89	15	8	20	15	8	22	15	8	32
9	31	27.85	18	8	20	18	8	22	18	8	32
10	34	30.82	20	8	20	20	8	22	20	10	32
11	37	33.8	22	8	25	22	10	25	22	10	35
12	40	36.8	25	8	25	25	10	25	25	10	35
13	43	39.79	28	10	25	28	10	25	28	10	35
14	46.3	42.8	31	10	25	31	10	25	31	12	35
15	49.3	45.81	34	10	25	34	10	25	34	12	35
16	52.3	48.82	37	10	28	37	12	30	37	12	35
17	55.3	51.83	40	10	28	40	12	30	40	12	35
18	58.3	54.85	43	10	28	43	12	30	43	12	35
19	61.3	57.87	45	10	28	46	12	30	46	12	35
20	64.3	60.89	48	10	28	49	12	30	49	12	35
21	68	63.91	50	12	28	52	12	30	52	14	40
22	71	66.93	52	12	28	55	12	30	55	14	40
23	73.5	69.95	54	12	28	58	12	30	58	14	40
24	77	72.97	57	12	28	61	12	30	61	14	40
25	80	76	60	12	28	64	12	30	64	14	40
26	83	79.02	60	12	28	67	12	30	67	14	40
27	86	82.05	60	12	28	70	12	30	70	14	40
28	89	85.07	60	12	28	73	12	30	73	14	40
29	92	88.09	60	12	28	76	12	30	76	14	40
30	94.7	91.12	60	12	28	79	12	30	79	14	40
31	98.3	94.15	65	14	30	80	16	30	80	16	40
32	101.3	97.17	65	14	30	80	16	30	80	16	40
33	104.3	100.2	65	14	30	80	16	30	80	16	40
34	107.3	103.23	65	14	30	80	16	30	85	16	40
35	110.4	106.26	65	14	30	80	16	30	85	16	40
36	113.4	109.29	70	14	30	90	16	30	90	16	40
37	116.4	112.32	70	14	30	90	16	30	90	16	40
38	119.5	115.35	70	14	30	90	16	30	90	16	40
39	122.5	118.37	70	14	30	90	16	30	90	16	40
40	125.5	121.4	70	14	30	90	16	30	90	16	40



Sprockets for Roller Chains DIN8187-ISO/R606

3/8" x 7/32" mm

06A-1 -2 -3

CHAIN 配套链条尺寸: Pitch 节距: 9.525mm
 Internal width 内链板宽度: 5.72 mm
 Roller dia. 滚径: 6.35 mm

SPROCKET 链轮尺寸: Tooth radius 齿半径 r: 10 mm
 Radius width 圆弧倒角宽度 C: 1 mm
 Tooth width 齿宽 h1: 5.3 mm
 Tooth width 齿宽 L: 5.2 mm
 Tooth width 齿宽 h2: 15.4 mm
 Tooth width 齿宽 h3: 25.6 mm
 Full height 总高 H:-

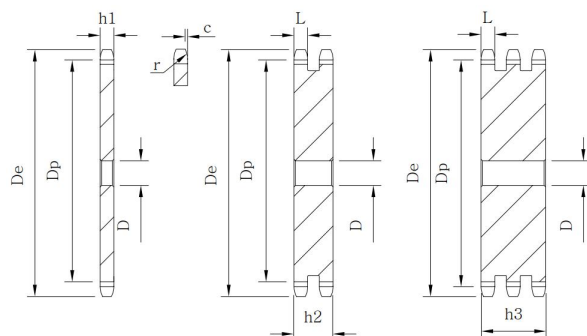

Teeth	齿数	De 外径	Dp 节径	Simplex 单排	Duplex 双排	Triplex 三排
				D 内孔	D 内孔	D 内孔
8		28	24.89	6	8	8
9		31	27.85	8	8	8
10		34	30.82	8	8	10
11		37	33.8	8	10	10
12		40	36.8	8	10	10
13		43	39.79	8	10	10
14		46.3	42.8	8	10	12
15		49.3	45.81	8	10	12
16		52.3	48.82	10	12	12
17		55.3	51.83	10	12	12
18		58.3	54.85	10	12	12
19		61.3	57.87	10	12	12
20		64.3	60.89	10	12	12
21		68	63.91	10	12	12
22		71	66.93	10	12	14
23		73.5	69.95	10	12	14
24		77	72.97	10	12	14
25		80	76	10	12	14
26		83	79.02	10	12	14
27		86	82.05	10	12	14
28		89	85.07	10	12	14
29		92	88.09	10	12	14
30		94.7	91.12	10	12	14
31		98.3	94.15	12	14	16
32		101.3	97.17	12	14	16
33		104.3	100.2	12	14	16
34		107.3	103.23	12	14	16
35		110.4	106.26	12	14	16
36		113.4	109.29	12	14	16
37		116.4	112.32	12	14	16
38		119.5	115.35	12	14	16
39		122.5	118.37	12	14	16
40		125.5	121.4	12	14	16



Sprockets for Roller Chains DIN8187-ISO/R606

1/2" x 1/8" mm

081B-1

CHAIN 配套链条尺寸: Pitch 节距: 12.7 mm
 Internal width 内链板宽度: 3.3 mm
 Roller dia. 滚径: 7.75 mm

SPROCKET 链轮尺寸: Tooth radius 齿半径 r: 13 mm
 Radius width 圆弧倒角宽度 C: 1.3 mm
 Tooth width 齿宽 h1: 3 mm
 Tooth width 齿宽 L: -
 Tooth width 齿宽 h2: -
 Tooth width 齿宽 h3: -
 Full height 总高 H:-

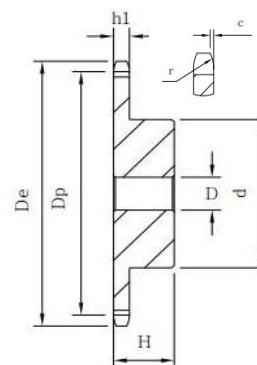

Teeth	齿数	De 外径	Dp 节径	Simplex 单排		
				d 搭径	D 内孔	H 总高
8		37.2	33.18	21	8	14
9		41.5	37.13	25	8	14
10		46.2	41.1	28	8	14
11		49.6	45.07	31	8	16
12		53.9	49.07	35	8	16
13		58.4	53.06	39	8	16
14		62.8	57.07	43	8	16
15		66.8	61.09	47	8	16
16		70.9	65.1	50	10	18
17		74.9	69.11	50	10	18
18		78.9	73.14	50	10	18
19		82.9	77.16	50	10	18
20		86.9	81.19	50	10	18
21		91	85.22	60	12	20
22		95	89.24	60	12	20
23		99	93.27	60	12	20
24		103	97.29	60	12	20
25		107.1	101.33	60	12	20
26		111.2	105.36	70	16	20
27		115.4	109.4	70	16	20
28		119.4	113.42	70	16	20
29		123.4	117.46	70	16	20
30		127.5	121.5	70	16	20
31		131.5	125.54	70	16	20
32		135.5	129.56	70	16	20
33		139.6	133.6	70	16	20
34		143.6	137.64	70	16	20
35		147.6	141.68	70	16	20
36		151.7	145.72	70	16	25
37		155.7	149.76	70	16	25
38		159.8	153.8	70	16	25
39		163.8	157.83	70	16	25
40		167.8	161.87	70	16	25



Sprockets for Roller Chains DIN8187-ISO/R606

1/2" x 1/8" mm

081A-1

CHAIN 配套链条尺寸: Pitch 节距: 12.7 mm
 Internal width 内链板宽度: 3.3 mm
 Roller dia. 滚径: 7.75 mm

SPROCKET 链轮尺寸: Tooth radius 齿半径 r: 13 mm
 Radius width 圆弧倒角宽度 C: 1.3 mm
 Tooth width 齿宽 h1: 3 mm
 Tooth width 齿宽 L: -
 Tooth width 齿宽 h2: -
 Tooth width 齿宽 h3: -
 Full height 总高 H:-

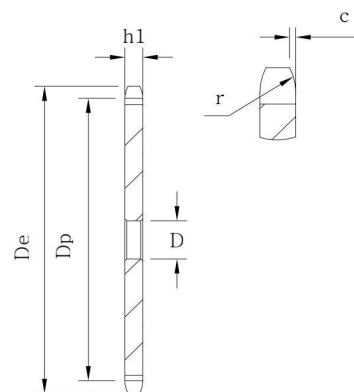

Teeth	齿数	De 外径	Dp 节径	Simplex 单排		
				D 内孔		
8		37.2	33.18	8		
9		41.5	37.13	8		
10		46.2	41.1	8		
11		49.6	45.07	8		
12		53.9	49.07	8		
13		58.4	53.06	8		
14		62.8	57.07	8		
15		66.8	61.09	8		
16		70.9	65.1	8		
17		74.9	69.11	8		
18		78.9	73.14	8		
19		82.9	77.16	8		
20		86.9	81.19	8		
21		91	85.22	8		
22		95	89.24	10		
23		99	93.27	10		
24		103	97.29	10		
25		107.1	101.33	10		
26		111.2	105.36	12		
27		115.4	109.4	12		
28		119.4	113.42	12		
29		123.4	117.46	12		
30		127.5	121.5	12		
31		131.5	125.54	12		
32		135.5	129.56	12		
33		139.6	133.6	12		
34		143.6	137.64	12		
35		147.6	141.68	12		
36		151.7	145.72	16		
37		155.7	149.76	16		
38		159.8	153.8	16		
39		163.8	157.83	16		
40		167.8	161.87	16		



Sprockets for Roller Chains DIN8187-ISO/R606

1/2" x 3/16" mm

083B/084B-1

CHAIN 配套链条尺寸: Pitch 节距: 12.7 mm
 Internal width 内链板宽度: 4.88 mm
 Roller dia. 滚径: 7.75 mm

SPROCKET 链轮尺寸: Tooth radius 齿半径 r: 13 mm
 Radius width 圆弧倒角宽度 C: 1.3 mm
 Tooth width 齿宽 h1: 4.5 mm
 Tooth width 齿宽 L: -
 Tooth width 齿宽 h2: -
 Tooth width 齿宽 h3: -
 Full height 总高 H:-

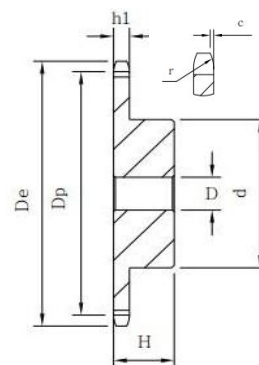

Teeth	齿数	De 外径	Dp 节径	Simplex 单排		
				d 搭径	D 内孔	H 总高
8		38.5	33.18	21	8	14
9		41.5	37.13	25	8	14
10		46.2	41.1	28	8	14
11		49.6	45.07	31	8	16
12		53.9	49.07	35	8	16
13		58.4	53.06	39	8	16
14		62.8	57.07	43	8	16
15		66.8	61.09	47	8	16
16		70.9	65.1	50	10	18
17		74.9	69.11	50	10	18
18		78.9	73.14	50	10	18
19		82.9	77.16	50	10	18
20		86.9	81.19	50	10	18
21		91	85.22	60	12	20
22		95	89.24	60	12	20
23		99	93.27	60	12	20
24		103	97.29	60	12	20
25		107.1	101.33	60	12	20
26		111.2	105.36	70	16	20
27		115.4	109.4	70	16	20
28		119.4	113.42	70	16	20
29		123.4	117.46	70	16	20
30		127.5	121.5	70	16	20
31		131.5	125.54	70	16	20
32		135.5	129.56	70	16	20
33		139.6	133.6	70	16	20
34		143.6	137.64	70	16	20
35		147.6	141.68	70	16	20
36		151.7	145.72	70	16	25
37		155.7	149.76	70	16	25
38		159.8	153.8	70	16	25
39		163.8	157.83	70	16	25
40		167.8	161.87	70	16	25



Sprockets for Roller Chains DIN8187-ISO/R606

1/2" x 3/16" mm

083B/084A-1

CHAIN 配套链条尺寸: Pitch 节距: 12.7 mm
 Internal width 内链板宽度: 4.88 mm
 Roller dia. 滚径: 7.75 mm

SPROCKET 链轮尺寸: Tooth radius 齿半径 r: 13 mm
 Radius width 圆弧倒角宽度 C: 1.3 mm
 Tooth width 齿宽 h1: 4.5 mm
 Tooth width 齿宽 L: -
 Tooth width 齿宽 h2: -
 Tooth width 齿宽 h3: -
 Full height 总高 H:-

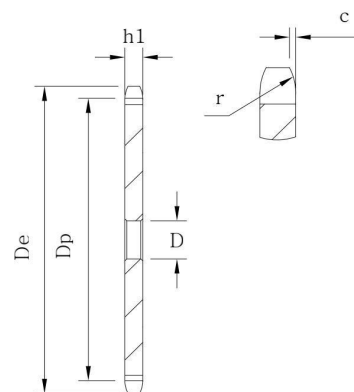

Teeth	齿数	De 外径	Dp 节径	Simplex 单排		
				D 内孔		
8		38.5	33.18	8		
9		41.5	37.13	8		
10		46.2	41.1	8		
11		49.6	45.07	8		
12		53.9	49.07	8		
13		58.4	53.06	8		
14		62.8	57.07	8		
15		66.8	61.09	8		
16		70.9	65.1	8		
17		74.9	69.11	8		
18		78.9	73.14	8		
19		82.9	77.16	8		
20		86.9	81.19	8		
21		91	85.22	8		
22		95	89.24	10		
23		99	93.27	10		
24		103	97.29	10		
25		107.1	101.33	10		
26		111.2	105.36	12		
27		115.4	109.4	12		
28		119.4	113.42	12		
29		123.4	117.46	12		
30		127.5	121.5	12		
31		131.5	125.54	12		
32		135.5	129.56	12		
33		139.6	133.6	12		
34		143.6	137.64	12		
35		147.6	141.68	12		
36		151.7	145.72	16		
37		155.7	149.76	16		
38		159.8	153.8	16		
39		163.8	157.83	16		
40		167.8	161.87	16		



Sprockets for Roller Chains DIN8187-ISO/R606

1/2" x 5/16" mm

08B-1 -2 -3

CHAIN 配套链条尺寸: Pitch 节距: 12.7 mm
 Internal width 内链板宽度: 7.75 mm
 Roller dia. 滚径: 8.51 mm

SPROCKET 链轮尺寸: Tooth radius 齿半径 r: 13 mm
 Radius width 圆弧倒角宽度 C: 1.3 mm
 Tooth width 齿宽 h1: 7.2 mm
 Tooth width 齿宽 L: 7 mm
 Tooth width 齿宽 h2: 21 mm
 Tooth width 齿宽 h3: 34.9 mm
 Full height 总高 H:-

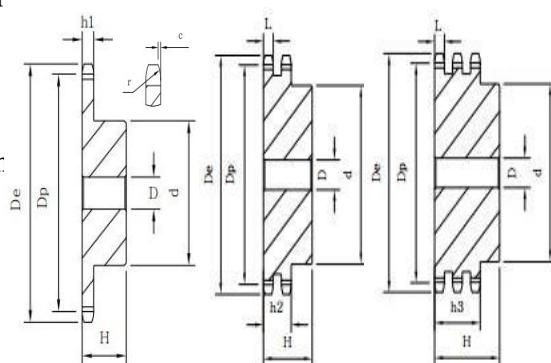

Teeth 齿数	De 外径	Dp 节径	Simplex 单排			Duplex 双排			Triplex 三排		
			d 搭径	D 内孔	H 总高	d 搭径	D 内孔	H 总高	d 搭径	D 内孔	H 总高
8	37.2	33.18	20	10	25	20	10	32	20	10	46
9	41	37.13	24	10	25	24	10	32	24	12	46
10	45.2	41.1	26	10	25	28	10	32	28	12	46
11	48.7	45.07	29	10	25	32	12	35	32	14	50
12	53	49.07	33	10	28	35	12	35	35	14	50
13	57.4	53.06	37	10	28	38	12	35	38	14	50
14	61.8	57.07	41	10	28	42	12	35	42	14	50
15	65.5	61.09	45	10	28	46	12	35	46	14	50
16	69.5	65.1	50	12	28	50	14	35	50	16	50
17	73.6	69.11	52	12	28	54	14	35	54	16	50
18	77.8	73.14	56	12	28	58	14	35	58	16	50
19	81.7	77.16	60	12	28	62	14	35	62	16	50
20	85.8	81.19	64	12	28	66	14	35	66	16	50
21	89.7	85.22	68	12	28	70	16	40	70	16	55
22	93.8	89.24	70	12	28	70	16	40	70	16	55
23	98.2	93.27	70	14	28	70	16	40	70	16	55
24	101.8	97.29	70	14	28	75	16	40	75	16	55
25	105.8	101.33	70	14	28	80	16	40	80	16	55
26	110	105.36	70	16	30	85	16	40	85	20	55
27	114	109.4	70	16	30	85	16	40	85	20	55
28	118	113.42	70	16	30	90	16	40	90	20	55
29	122	117.46	80	16	30	95	16	40	95	20	55
30	126.1	121.5	80	16	30	100	16	40	100	20	55
31	130.2	125.54	90	16	30	100	20	40	110	20	55
32	134.3	129.56	90	16	30	100	20	40	110	20	55
33	138.4	133.6	90	16	30	100	20	40	110	20	55
34	142.6	137.64	90	16	30	100	20	40	110	20	55
35	146.7	141.68	90	16	30	100	20	40	110	20	55
36	151	145.72	90	16	35	100	20	40	120	25	55
37	154.6	149.76	90	16	35	100	20	40	120	25	55
38	158.6	153.8	90	16	35	100	20	40	120	25	55
39	162.7	157.83	90	16	35	100	20	40	120	25	55
40	166.8	161.87	90	16	35	100	20	40	120	25	55



Sprockets for Roller Chains DIN8187-ISO/R606

1/2" x 5/16" mm

08A-1 -2 -3

CHAIN 配套链条尺寸: Pitch 节距: 12.7 mm
 Internal width 内链板宽度: 7.75 mm
 Roller dia. 滚径: 8.51 mm

SPROCKET 链轮尺寸: Tooth radius 齿半径 r: 13 mm
 Radius width 圆弧倒角宽度 C: 1.3 mm
 Tooth width 齿宽 h1: 7.2 mm
 Tooth width 齿宽 L: 7 mm
 Tooth width 齿宽 h2: 21 mm
 Tooth width 齿宽 h3: 34.9 mm
 Full height 总高 H:-

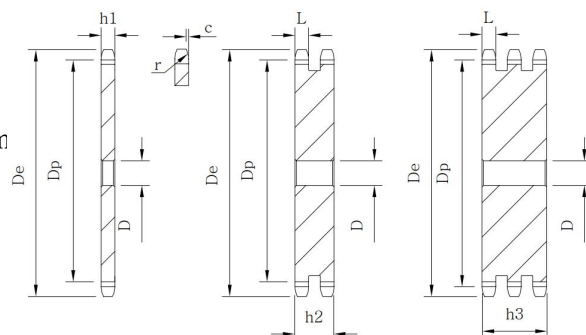

Teeth	齿数	De 外径	Dp 节径	Simplex 单排	Duplex 双排	Triplex 三排
				D 内孔	D 内孔	D 内孔
8		37.2	33.18	8	10	10
9		41	37.13	8	10	10
10		45.2	41.1	8	10	10
11		48.7	45.07	10	10	12
12		53	49.07	10	10	12
13		57.4	53.06	10	10	12
14		61.8	57.07	10	10	12
15		65.5	61.09	10	10	12
16		69.5	65.1	10	12	16
17		73.6	69.11	10	12	16
18		77.8	73.14	10	12	16
19		81.7	77.16	10	12	16
20		85.8	81.19	10	12	16
21		89.7	85.22	12	16	16
22		93.8	89.24	12	16	16
23		98.2	93.27	12	16	16
24		101.8	97.29	12	16	16
25		105.8	101.33	12	16	16
26		110	105.36	16	16	16
27		114	109.4	16	16	16
28		118	113.42	16	16	16
29		122	117.46	16	16	16
30		126.1	121.5	16	16	16
31		130.2	125.54	16	16	20
32		134.3	129.56	16	16	20
33		138.4	133.6	16	16	20
34		142.6	137.64	16	16	20
35		146.7	141.68	16	16	20
36		151	145.72	16	20	20
37		154.6	149.76	16	20	20
38		158.6	153.8	16	20	20
39		162.7	157.83	16	20	20
40		166.8	161.87	16	20	20



Sprockets for Roller Chains DIN8187-ISO/R606

5/8" x 3/8" mm

10B-1 -2 -3

CHAIN 配套链条尺寸: Pitch 节距: 15.875 mm
 Internal width 内链板宽度: 9.65 mm
 Roller dia. 滚径: 10.16 mm

SPROCKET 链轮尺寸: Tooth radius 齿半径 r: 16 mm
 Radius width 圆弧倒角宽度 C: 1.6 mm
 Tooth width 齿宽 h1: 9.1 mm
 Tooth width 齿宽 L: 9 mm
 Tooth width 齿宽 h2: 25.5 mm
 Tooth width 齿宽 h3: 42.1 mm
 Full height 总高 H:-

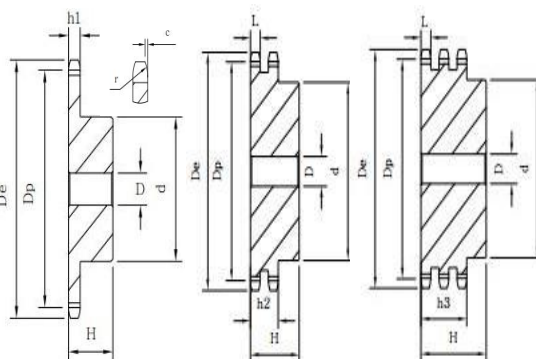

Teeth 齿数	De 外径	Dp 节径	Simplex 单排			Duplex 双排			Triplex 三排		
			d 搭径	D 内孔	H 总高	d 搭径	D 内孔	H 总高	d 搭径	D 内孔	H 总高
8	47	41.48	25	10	25	25	12	40	25	12	55
9	52.6	46.42	30	10	25	30	12	40	30	12	55
10	57.5	51.37	35	10	25	35	12	40	35	12	55
11	63	56.34	37	12	30	39	14	40	39	16	55
12	68	61.34	42	12	30	44	14	40	44	16	55
13	73	66.32	47	12	30	49	14	40	49	16	55
14	78	71.34	52	12	30	54	14	40	54	16	55
15	83	76.36	57	12	30	59	14	40	59	16	55
16	88	81.37	60	12	30	64	16	45	64	16	60
17	93	86.39	60	12	30	69	16	45	69	16	60
18	98.3	91.42	70	14	30	74	16	45	74	16	60
19	103.3	96.45	70	14	30	79	16	45	79	16	60
20	108.4	101.49	75	14	30	84	16	45	84	16	60
21	113.4	106.52	75	16	30	85	16	45	85	20	60
22	118	111.55	80	16	30	90	16	45	90	20	60
23	123.5	116.58	80	16	30	95	16	45	95	20	60
24	128.3	121.62	80	16	30	100	16	45	100	20	60
25	134	126.66	80	16	30	105	16	45	105	20	60
26	139	131.7	85	20	35	110	20	45	110	20	60
27	144	136.75	85	20	35	110	20	45	110	20	60
28	148.7	141.78	90	20	35	115	20	45	115	20	60
29	153.8	146.83	90	20	35	115	20	45	115	20	60
30	158.8	151.87	90	20	35	120	20	45	120	20	60
31	163.9	156.92	95	20	35	120	20	45	120	20	60
32	168.9	161.95	95	20	35	120	20	45	120	20	60
33	174.5	167	95	20	35	120	20	45	120	20	60
34	179	172.05	95	20	35	120	20	45	120	20	60
35	184.1	177.1	95	20	35	120	20	45	120	20	60
36	189.1	182.15	100	20	35	120	20	45	120	25	60
37	194.2	187.2	100	20	35	120	20	45	120	25	60
38	199.2	192.24	100	20	35	120	20	45	120	25	60
39	204.2	197.29	100	20	35	120	20	45	120	25	60
40	209.3	202.34	100	20	35	120	20	45	120	25	60



Sprockets for Roller Chains DIN8187-ISO/R606

5/8" x 3/8" mm

10A-1 -2 -3

CHAIN 配套链条尺寸: Pitch 节距: 15.875 mm
 Internal width 内链板宽度: 9.65 mm
 Roller dia. 滚径: 10.16 mm

SPROCKET 链轮尺寸: Tooth radius 齿半径 r: 16 mm
 Radius width 圆弧倒角宽度 C: 1.6 mm
 Tooth width 齿宽 h1: 9.1 mm
 Tooth width 齿宽 L: 9 mm
 Tooth width 齿宽 h2: 25.5 mm
 Tooth width 齿宽 h3: 42.1 mm
 Full height 总高 H:-

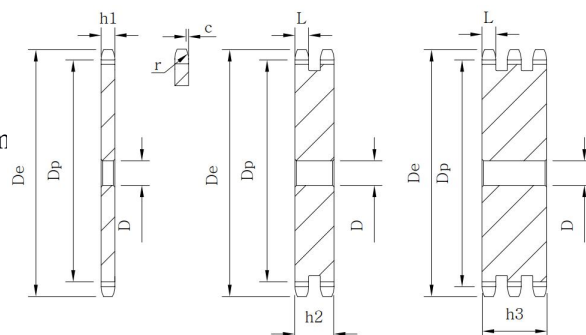

Teeth	齿数	De 外径	Dp 节径	Simplex 单排	Duplex 双排	Triplex 三排
				D 内孔	D 内孔	D 内孔
8		47	41.48	10	10	12
9		52.6	46.42	10	10	12
10		57.5	51.37	10	10	12
11		63	56.34	10	10	12
12		68	61.34	10	10	12
13		73	66.32	10	10	12
14		78	71.34	10	10	12
15		83	76.36	10	12	12
16		88	81.37	12	12	16
17		93	86.39	12	12	16
18		98.3	91.42	12	12	16
19		103.3	96.45	12	12	16
20		108.4	101.49	12	12	16
21		113.4	106.52	12	16	16
22		118	111.55	12	16	16
23		123.5	116.58	12	16	16
24		128.3	121.62	12	16	16
25		134	126.66	12	16	16
26		139	131.7	16	16	20
27		144	136.75	16	16	20
28		148.7	141.78	16	16	20
29		153.8	146.83	16	16	20
30		158.8	151.87	16	20	20
31		163.9	156.92	16	20	20
32		168.9	161.95	16	20	20
33		174.5	167	16	20	20
34		179	172.05	16	20	20
35		184.1	177.1	16	20	20
36		189.1	182.15	20	20	25
37		194.2	187.2	20	20	25
38		199.2	192.24	20	20	25
39		204.2	197.29	20	20	25
40		209.3	202.34	20	20	25



Sprockets for Roller Chains DIN8187-ISO/R606

3/4" x 7/16" mm

12B-1 -2 -3

CHAIN 配套链条尺寸: Pitch 节距: 19.05 mm
 Internal width 内链板宽度: 11.68 mm
 Roller dia. 滚径: 12.07 mm

SPROCKE 链轮尺寸: Tooth radius 齿半径 r: 19 mm
 Radius width 圆弧倒角宽度 C: 2 mm
 Tooth width 齿宽 h1: 11.1 mm
 Tooth width 齿宽 L: 10.8 mm
 Tooth width 齿宽 h2: 30.3 mm
 Tooth width 齿宽 h3: 49.8 mm
 Full height 总高 H:-

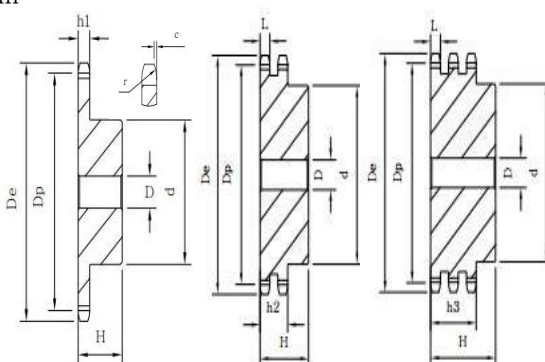

Teeth 齿数	De 外径	Dp 节径	Simplex 单排			Duplex 双排			Triplex 三排		
			d 搭径	D 内孔	H 总高	d 搭径	D 内孔	H 总高	d 搭径	D 内孔	H 总高
8	57.6	49.78	31	12	30	31	12	45	31	16	65
9	62	55.7	37	12	30	37	12	45	37	16	65
10	69	61.64	42	12	30	42	12	45	42	16	65
11	75	67.61	46	14	35	47	16	50	47	20	70
12	81.5	73.61	52	14	35	53	16	50	53	20	70
13	87.5	79.59	58	14	35	59	16	50	59	20	70
14	93.6	85.61	64	14	35	65	16	50	65	20	70
15	99.8	91.63	70	14	35	71	16	50	71	20	70
16	105.5	97.65	75	16	35	77	20	50	77	20	70
17	111.5	103.67	80	16	35	83	20	50	83	20	70
18	118	109.71	80	16	35	89	20	50	89	20	70
19	124.2	115.75	80	16	35	95	20	50	95	20	70
20	129.7	121.78	80	16	35	100	20	50	100	20	70
21	136	127.82	90	20	40	100	20	50	100	20	70
22	141	133.86	90	20	40	100	20	50	100	20	70
23	149	139.9	90	20	40	110	20	50	110	20	70
24	153.9	145.94	90	20	40	110	20	50	110	20	70
25	160	152	90	20	40	120	20	50	120	20	70
26	165.9	158.04	95	20	40	120	20	50	120	20	70
27	172.3	164.09	95	20	40	120	20	50	120	20	70
28	178	170.13	95	20	40	120	20	50	120	20	70
29	184.1	176.19	95	20	40	120	20	50	120	20	70
30	190.5	182.25	95	20	40	120	20	50	120	20	70
31	196.3	188.31	95	20	40	120	20	50	130	25	70
32	203.3	194.35	95	20	40	120	20	50	130	25	70
33	209.3	200.4	95	20	40	120	20	50	130	25	70
34	214.6	206.46	95	20	40	120	20	50	130	25	70
35	221	212.52	95	20	40	120	20	50	130	25	70
36	226.8	218.58	100	20	40	120	25	50	130	25	70
37	232.9	224.64	100	20	40	120	25	50	130	25	70
38	239	230.69	100	20	40	120	25	50	130	25	70
39	245.1	236.75	100	20	40	120	25	50	130	25	70
40	251.3	242.81	100	20	40	120	25	50	130	25	70



Sprockets for Roller Chains DIN8187-ISO/R606

3/4" x 7/16" mm

12A-1 -2 -3

CHAIN 配套链条尺寸: Pitch 节距: 19.05 mm
 Internal width 内链板宽度: 11.68 mm
 Roller dia. 滚径: 12.07 mm

SPROCKET 链轮尺寸: Tooth radius 齿半径 r: 19 mm
 Radius width 圆弧倒角宽度 C: 2 mm
 Tooth width 齿宽 h1: 11.1 mm
 Tooth width 齿宽 L: 10.8 mm
 Tooth width 齿宽 h2: 30.3 mm
 Tooth width 齿宽 h3: 49.8 mm
 Full height 总高 H:-

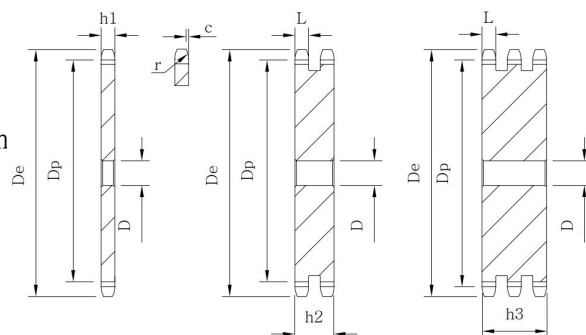

Teeth	齿数	De 外径	Dp 节径	Simplex 单排	Duplex 双排	Triplex 三排
				D 内孔	D 内孔	D 内孔
8		57.6	49.78	10	12	12
9		62	55.7	10	12	12
10		69	61.64	10	12	12
11		75	67.61	12	14	12
12		81.5	73.61	14	14	16
13		87.5	79.59	14	14	16
14		93.6	85.61	14	14	16
15		99.8	91.63	14	14	16
16		105.5	97.65	14	16	16
17		111.5	103.67	14	16	16
18		118	109.71	14	16	16
19		124.2	115.75	14	16	16
20		129.7	121.78	14	16	16
21		136	127.82	16	16	20
22		141	133.86	16	16	20
23		149	139.9	16	16	20
24		153.9	145.94	16	16	20
25		160	152	16	16	20
26		165.9	158.04	16	20	20
27		172.3	164.09	16	20	20
28		178	170.13	16	20	20
29		184.1	176.19	16	20	20
30		190.5	182.25	16	20	20
31		196.3	188.31	20	20	25
32		203.3	194.35	20	20	25
33		209.3	200.4	20	20	25
34		214.6	206.46	20	20	25
35		221	212.52	20	20	25
36		226.8	218.58	20	25	25
37		232.9	224.64	20	25	25
38		239	230.69	20	25	25
39		245.1	236.75	20	25	25
40		251.3	242.81	20	25	25



Sprockets for Roller Chains DIN8187-ISO/R606

1" x 17.02 mm

16B-1 -2 -3

CHAIN 配套链条尺寸: Pitch 节距: 25.4 mm
 Internal width 内链板宽度: 17.02 mm
 Roller dia. 滚径: 15.88 mm

SPROCKET 链轮尺寸: Tooth radius 齿半径 r: 26 mm
 Radius width 圆弧倒角宽度 C: 2.5 mm
 Tooth width 齿宽 h1: 16.2 mm
 Tooth width 齿宽 L: 15.8 mm
 Tooth width 齿宽 h2: 47.7 mm
 Tooth width 齿宽 h3: 79.6 mm
 Full height 总高 H:-

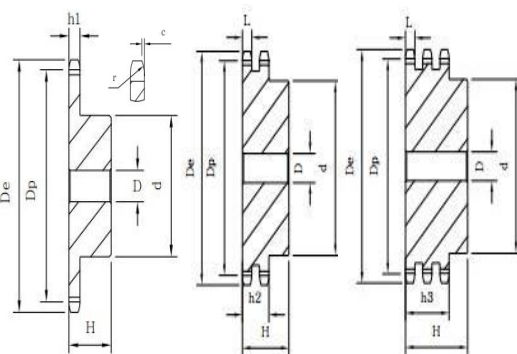

Material: C45 *Weld on hub

Teeth 齿数	De 外径	Dp 节径	Simplex 单排			Duplex 双排			Triplex 三排		
			d 搭径	D 内孔	H 总高	d 搭径	D 内孔	H 总高	d 搭径	D 内孔	H 总高
8	77	66.37	42	16	35	42	16	65	42	20	95
9	85	74.27	50	16	35	50	16	65	50	20	95
10	93	82.19	55	16	35	56	16	65	56	20	95
11	101.5	90.14	61	16	40	64	20	70	64	25	100
12	109	98.14	69	16	40	72	20	70	72	25	100
13	117	106.12	78	16	40	80	20	70	80	25	100
14	125	114.15	84	16	40	88	20	70	88	25	100
15	133	122.17	92	16	40	96	20	70	96	25	100
16	141	130.2	100	20	45	104	20	70	104	25	100
17	149	138.22	100	20	45	112	20	70	112	25	100
18	157	146.28	100	20	45	120	20	70	120	25	100
19	165.2	154.33	100	20	45	128	20	70	128	25	100
20	173.2	162.38	100	20	45	130	20	70	130	25	100
21	181.2	170.43	110	20	50	*130	25	70	*130	25	100
22	189.3	178.48	110	20	50	*130	25	70	*130	25	100
23	197.5	186.53	110	20	50	*130	25	70	*130	25	100
24	205.5	194.59	110	20	50	*130	25	70	*130	25	100
25	213.5	202.66	110	20	50	*130	25	70	*130	25	100
26	221.6	210.72	120	20	50	*130	25	70	*130	30	100
27	229.6	218.79	120	20	50	*130	25	70	*130	30	100
28	237.7	226.85	120	20	50	*130	25	70	*130	30	100
29	245.8	234.92	120	20	50	*130	25	70	*130	30	100
30	254	243	120	20	50	*130	25	70	*130	30	100
31	262	251.08	*120	25	50	*140	25	70	*140	30	100
32	270	259.13	*120	25	50	*140	25	70	*140	30	100
33	278.5	267.21	*120	25	50	*140	25	70	*140	30	100
34	287	275.28	*120	25	50	*140	25	70	*140	30	100
35	296.2	283.36	*120	25	50	*140	25	70	*140	30	100
36	304.6	291.44	*120	25	50	*140	25	70	*140	30	100
37	312.6	299.51	*120	25	50	*140	25	70	*140	30	100
38	320.7	307.59	*120	25	50	*140	25	70	*140	30	100
39	328.8	315.67	*120	25	50	*140	25	70	*140	30	100
40	336.9	323.75	*120	25	50	*140	25	70	*140	30	100



Sprockets for Roller Chains DIN8187-ISO/R606

1" x 17.02 mm

16A-1 -2 -3

CHAIN 配套链条尺寸: Pitch 节距: 25.4 mm
 Internal width 内链板宽度: 17.02 mm
 Roller dia. 滚径: 15.88 mm

SPROCKET 链轮尺寸: Tooth radius 齿半径 r: 26 mm
 Radius width 圆弧倒角宽度 C: 2.5 mm
 Tooth width 齿宽 h1: 16.2 mm
 Tooth width 齿宽 L: 15.8 mm
 Tooth width 齿宽 h2: 47.7 mm
 Tooth width 齿宽 h3: 79.6 mm
 Full height 总高 H:-

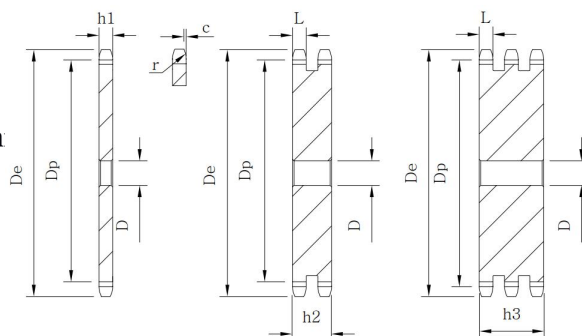

Teeth	齿数	De 外径	Dp 节径	Simplex 单排	Duplex 双排	Triplex 三排
				D 内孔	D 内孔	D 内孔
8		77	66.37	12	16	16
9		85	74.27	12	16	16
10		93	82.19	12	16	16
11		101.5	90.14	16	20	20
12		109	98.14	16	20	20
13		117	106.12	16	20	20
14		125	114.15	16	20	20
15		133	122.17	16	20	20
16		141	130.2	20	20	25
17		149	138.22	20	20	25
18		157	146.28	20	20	25
19		165.2	154.33	20	20	25
20		173.2	162.38	20	20	25
21		181.2	170.43	20	25	25
22		189.3	178.48	20	25	25
23		197.5	186.53	20	25	25
24		205.5	194.59	20	25	25
25		213.5	202.66	20	25	25
26		221.6	210.72	20	25	30
27		229.6	218.79	20	25	30
28		237.7	226.85	20	25	30
29		245.8	234.92	20	25	30
30		254	243	20	25	30
31		262	251.08	25	25	30
32		270	259.13	25	25	30
33		278.5	267.21	25	25	30
34		287	275.28	25	25	30
35		296.2	283.36	25	25	30
36		304.6	291.44	25	25	30
37		312.6	299.51	25	25	30
38		320.7	307.59	25	25	30
39		328.8	315.67	25	25	30
40		336.9	323.75	25	25	30



Sprockets for Roller Chains DIN8187-ISO/R606

1" 1/4 x 3/4 mm

20B-1 -2 -3

CHAIN 配套链条尺寸: Pitch 节距: 31.75 mm
 Internal width 内链板宽度: 19.56 mm
 Roller dia. 滚径: 19.05 mm

SPROCKET 链轮尺寸: Tooth radius 齿半径 r: 32 mm
 Radius width 圆弧倒角宽度 C: 3.5 mm
 Tooth width 齿宽 h1: 18.5 mm
 Tooth width 齿宽 L: 18.2 mm
 Tooth width 齿宽 h2: 54.6 mm
 Tooth width 齿宽 h3: 91 mm
 Full height 总高 H:-

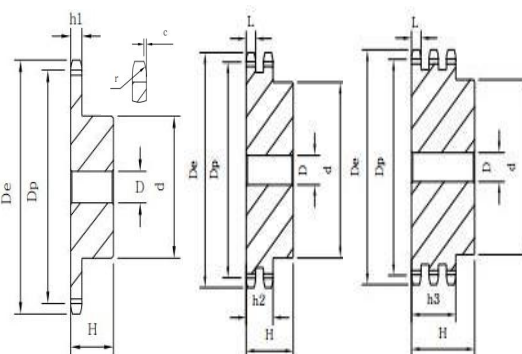

Material: C45 *Weld on hub

Teeth 齿数	De 外径	Dp 节径	Simplex 单排			Duplex 双排			Triplex 三排		
			d 搭径	D 内孔	H 总高	d 搭径	D 内孔	H 总高	d 搭径	D 内孔	H 总高
8	98.1	82.96	53	20	40	53	20	75	53	20	110
9	108	92.84	63	20	40	63	20	75	63	20	110
10	117.9	102.74	70	20	40	70	20	75	70	20	110
11	127.8	112.68	77	20	45	80	20	80	80	20	115
12	137.8	122.68	88	20	45	90	20	80	90	20	115
13	147.8	132.65	98	20	45	100	20	80	100	20	115
14	157.8	142.68	108	20	45	110	20	80	110	20	115
15	167.9	152.72	118	20	45	120	20	80	120	20	115
16	177.9	162.75	120	20	50	120	25	80	120	25	115
17	187.9	172.78	120	25	50	120	25	80	120	25	115
18	198	182.85	120	25	50	*120	25	80	*120	25	115
19	208.1	192.91	120	25	50	*120	25	80	*120	25	115
20	218.1	202.98	120	25	50	*120	25	80	*120	25	115
21	228.2	213.04	140	25	55	*140	25	80	*140	25	115
22	238.3	223.11	140	25	55	*140	25	80	*140	25	115
23	248.3	233.17	140	25	55	*140	25	80	*140	25	115
24	258.4	243.23	140	25	55	*140	25	80	*140	25	115
25	268.5	253.33	140	25	55	*140	25	80	*140	25	115
26	278.6	263.4	*150	25	55	*150	25	80	*150	25	115
27	288.6	273.49	*150	25	55	*150	25	80	*150	25	115
28	298.7	283.56	*150	25	55	*150	25	80	*150	25	115
29	308.8	293.65	*150	25	55	*150	25	80	*150	25	115
30	318.9	303.75	*150	25	55	*150	25	80	*150	25	115
31	329	313.85	*150	25	55	*150	25	80	*150	30	115
32	339.1	323.91	*150	25	55	*150	25	80	*150	30	115
33	349.2	334.01	*150	25	55	*150	25	80	*150	30	115
34	359.3	344.1	*150	25	55	*150	25	80	*150	30	115
35	369.4	354.2	*150	25	55	*150	25	80	*150	30	115
36	379.5	364.3	*150	25	55	*150	30	80	*150	30	115
37	389.5	374.39	*150	25	55	*150	30	80	*150	30	115
38	399.6	384.49	*150	25	55	*150	30	80	*150	30	115
39	409.7	394.56	*150	25	55	*150	30	80	*150	30	115
40	419.8	404.69	*150	25	55	*150	30	80	*150	30	115



Sprockets for Roller Chains DIN8187-ISO/R606

1" 1/4 x 3/4 mm

20A-1 -2 -3

CHAIN 配套链条尺寸: Pitch 节距: 31.75 mm
 Internal width 内链板宽度: 19.56 mm
 Roller dia. 滚径: 19.05 mm

SPROCKET 链轮尺寸: Tooth radius 齿半径 r: 32 mm
 Radius width 圆弧倒角宽度 C: 3.5 mm
 Tooth width 齿宽 h1: 18.5 mm
 Tooth width 齿宽 L: 18.2 mm
 Tooth width 齿宽 h2: 54.6 mm
 Tooth width 齿宽 h3: 91 mm
 Full height 总高 H:-

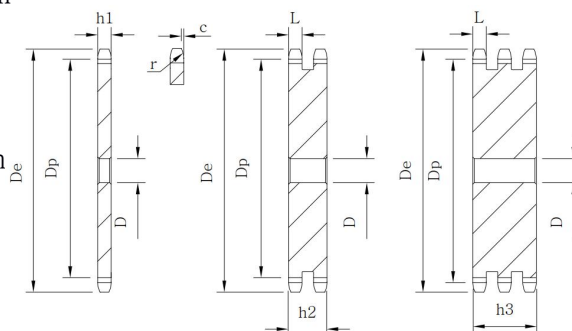

Teeth	齿数	De 外径	Dp 节径	Simplex 单排	Duplex 双排	Triplex 三排
				D 内孔	D 内孔	D 内孔
8		98.1	82.96	16	20	20
9		108	92.84	16	20	20
10		117.9	102.74	16	20	20
11		127.8	112.68	16	20	20
12		137.8	122.68	20	20	20
13		147.8	132.65	20	20	20
14		157.8	142.68	20	20	20
15		167.9	152.72	20	20	20
16		177.9	162.75	20	25	25
17		187.9	172.78	20	25	25
18		198	182.85	20	25	25
19		208.1	192.91	20	25	25
20		218.1	202.98	20	25	25
21		228.2	213.04	25	25	25
22		238.3	223.11	25	25	25
23		248.3	233.17	25	25	25
24		258.4	243.23	25	25	25
25		268.5	253.33	25	25	25
26		278.6	263.4	25	25	25
27		288.6	273.49	25	25	25
28		298.7	283.56	25	25	25
29		308.8	293.65	25	25	25
30		318.9	303.75	25	25	25
31		329	313.85	25	25	30
32		339.1	323.91	25	25	30
33		349.2	334.01	25	25	30
34		359.3	344.1	25	25	30
35		369.4	354.2	25	25	30
36		379.5	364.3	25	30	30
37		389.5	374.39	25	30	30
38		399.6	384.49	25	30	30
39		409.7	394.56	25	30	30
40		419.8	404.69	25	30	30



Sprockets for Roller Chains DIN8187-ISO/R606

1" 1/2 x 1" mm

24B-1 -2 -3

CHAIN 配套链条尺寸: Pitch 节距: 38.1 mm
 Internal width 内链板宽度: 25.4 mm
 Roller dia. 滚径: 25.4 mm

SPROCKET 链轮尺寸: Tooth radius 齿半径 r: 38 mm
 Radius width 圆弧倒角宽度 C: 4 mm
 Tooth width 齿宽 h1: 24.1mm
 Tooth width 齿宽 L: 23.6 mm
 Tooth width 齿宽 h2: 72 mm
 Tooth width 齿宽 h3: 120.3 mm
 Full height 总高 H:-

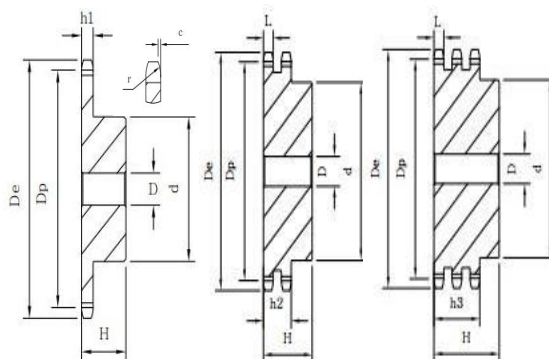

Material: C45 *Weld on hub

Teeth 齿数	De 外径	Dp 节径	Simplex 单排			Duplex 双排			Triplex 三排		
			d 搭径	D 内孔	H 总高	d 搭径	D 内孔	H 总高	d 搭径	D 内孔	H 总高
8	115	99.55	58	20	45	58	25	95	58	25	140
9	126.4	111.4	70	20	45	70	25	95	70	25	140
10	138	123.29	80	20	45	80	25	95	80	25	140
11	150	135.21	90	25	50	90	25	100	90	25	150
12	162	147.22	102	25	50	102	25	100	102	25	150
13	174.2	159.18	114	25	50	114	25	100	114	25	150
14	186.2	171.22	128	25	50	128	25	100	128	25	150
15	198.2	183.26	132	25	50	132	25	100	132	25	150
16	210.3	195.30	*136	25	55	*136	25	100	136	25	150
17	222.3	207.34	*136	25	55	*136	25	100	140	25	150
18	234.3	219.42	*136	25	55	*150	25	100	*150	25	150
19	246.5	231.49	*136	25	55	*160	25	100	*160	25	150
20	258.6	243.57	*136	25	55	*160	25	100	*160	25	150
21	270.6	255.65	*150	25	60	*160	25	100	*160	30	150
22	282.7	267.73	*150	25	60	*160	25	100	*160	30	150
23	294.8	279.8	*150	25	60	*160	25	100	*160	30	150
24	306.8	291.88	*150	25	60	*160	25	100	*160	30	150
25	319	304	*150	25	60	*160	25	100	*160	30	150
26	331	316.08	*150	30	60	*160	30	100	*160	30	150
27	343.2	328.19	*150	30	60	*160	30	100	*160	30	150
28	355.2	340.27	*150	30	60	*160	30	100	*160	30	150
29	367.3	352.38	*150	30	60	*160	30	100	*160	30	150
30	379.5	364.5	*150	30	60	*160	30	100	*160	30	150
31	391.6	376.62	*150	30	60	*160	30	100	*160	40	150
32	403.7	388.69	*150	30	60	*160	30	100	*160	40	150
33	415.8	400.81	*150	30	60	*160	30	100	*160	40	150
34	427.8	412.93	*150	30	60	*160	30	100	*160	40	150
35	440	425.04	*150	30	60	*160	30	100	*160	40	150
36	452	437.16	*150	30	60	*160	30	100	*160	40	150
37	464.2	449.27	*150	30	60	*160	30	100	*160	40	150
38	476.2	461.39	*150	30	60	*160	30	100	*160	40	150
39	488.5	473.5	*150	30	60	*160	30	100	*160	40	150
40	500.6	485.62	*150	30	60	*160	30	100	*160	40	150



Sprockets for Roller Chains DIN8187-ISO/R606

1" 1/2 x 1" mm

24A-1 -2 -3

CHAIN 配套链条尺寸: Pitch 节距: 38.1 mm
 Internal width 内链板宽度: 25.4 mm
 Roller dia. 滚径: 25.4 mm

SPROCKET 链轮尺寸: Tooth radius 齿半径 r: 38 mm
 Radius width 圆弧倒角宽度 C: 4 mm
 Tooth width 齿宽 h1: 24.1 mm
 Tooth width 齿宽 L: 23.6 mm
 Tooth width 齿宽 h2: 72 mm
 Tooth width 齿宽 h3: 120.3 mm
 Full height 总高 H:-

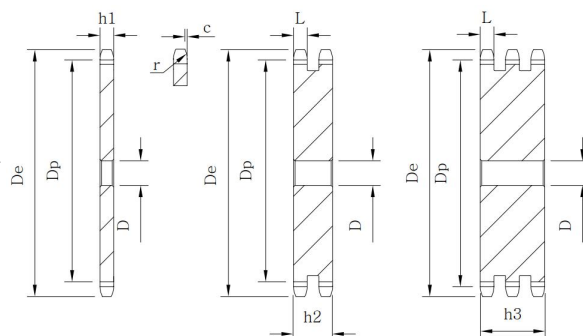

Teeth	齿数	De 外径	Dp 节径	Simplex 单排	Duplex 双排	Triplex 三排
				D 内孔	D 内孔	D 内孔
8		115	99.55	20	25	25
9		126.4	111.4	20	25	25
10		138	123.29	20	25	25
11		150	135.21	20	25	25
12		162	147.22	20	25	25
13		174.2	159.18	20	25	25
14		186.2	171.22	20	25	25
15		198.2	183.26	20	25	25
16		210.3	195.30	25	25	25
17		222.3	207.34	25	25	25
18		234.3	219.42	25	25	25
19		246.5	231.49	25	25	25
20		258.6	243.57	25	25	25
21		270.6	255.65	25	25	30
22		282.7	267.73	25	25	30
23		294.8	279.8	25	25	30
24		306.8	291.88	25	25	30
25		319	304	25	25	30
26		331	316.08	30	30	30
27		343.2	328.19	30	30	30
28		355.2	340.27	30	30	30
29		367.3	352.38	30	30	30
30		379.5	364.5	30	30	40
31		391.6	376.62	30	30	40
32		403.7	388.69	30	30	40
33		415.8	400.81	30	30	40
34		427.8	412.93	30	30	40
35		440	425.04	30	30	40
36		452	437.16	30	30	40
37		464.2	449.27	30	30	40
38		476.2	461.39	30	30	40
39		488.5	473.5	30	30	40
40		500.6	485.62	30	30	40



Sprockets for Roller Chains DIN8187-ISO/R606

1" 3/4 x 1" 1/4 mm

28B-1 -2 -3

CHAIN 配套链条尺寸: Pitch 节距: 44.45 mm
 Internal width 内链板宽度: 30.99 mm
 Roller dia. 滚径: 27.94 mm

SPROCKET 链轮尺寸: Tooth radius 齿半径 r: 44 mm
 Radius width 圆弧倒角宽度 C: 5 mm
 Tooth width 齿宽 h1: 29.4mm
 Tooth width 齿宽 L: 28.8 mm
 Tooth width 齿宽 h2: 88.4 mm
 Tooth width 齿宽 h3: 148 mm
 Full height 总高 H:-

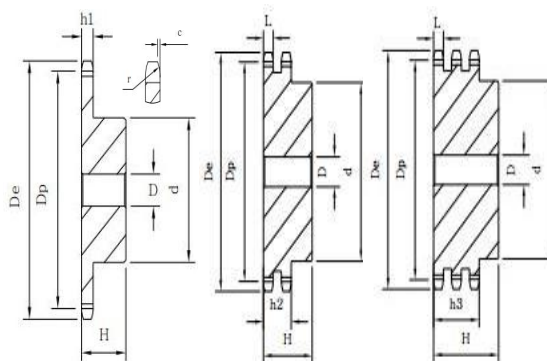

Material: C45 *Weld on hub

Teeth 齿数	De 外径	Dp 节径	Simplex 单排			Duplex 双排			Triplex 三排		
			d 搭径	D 内孔	H 总高	d 搭径	D 内孔	H 总高	d 搭径	D 内孔	H 总高
8	132	116.15	74	25	70	74	25	120	74	30	180
9	148.4	129.96	88	25	70	88	25	120	88	30	180
10	162.3	143.85	100	25	70	100	25	120	100	30	180
11	176.3	157.77	112	25	70	112	25	120	112	30	180
12	189.5	171.74	125	25	70	125	25	120	125	30	180
13	204.2	185.75	*125	25	70	*125	25	120	*125	30	180
14	218.2	199.76	*125	25	70	*125	25	120	*125	30	180
15	232.3	213.79	*125	25	70	*145	25	120	*145	30	180
16	246.3	227.84	*160	30	75	*160	30	120	*160	30	180
17	260.3	241.91	*160	30	75	*160	30	120	*160	30	180
18	274	255.98	*160	30	75	*160	30	120	*160	30	180
19	289	270.06	*160	30	75	*180	30	120	*180	30	180
20	303	284.15	*160	30	75	*180	30	120	*180	30	180
21	317	298.24	*160	30	75	*180	30	120	*180	30	180
22	331	312.34	*160	30	75	*180	30	120	*180	30	180
23	345	326.44	*160	30	75	*180	30	120	*180	30	180
24	359	340.55	*160	30	75	*180	30	120	*180	30	180
25	373	354.66	*160	30	75	*180	30	120	*180	40	180
26	387	368.77	*160	30	75	*180	30	120	*180	40	180
27	401.4	382.88	*160	30	75	*180	30	120	*180	40	180
28	416	397	*160	30	75	*180	30	120	*180	40	180
29	430	411.12	*160	30	75	*180	30	120	*180	40	180
30	444	425.24	*160	30	75	*180	30	120	*180	40	180
31	458	439.37	*180	30	75	*180	30	120	*180	40	180
32	472	453.49	*180	30	75	*180	30	120	*180	40	180
33	486	467.62	*180	30	75	*180	30	120	*180	40	180
34	500	481.75	*180	30	75	*180	30	120	*180	40	180
35	514	495.88	*180	30	75	*200	30	120	*200	40	180
36	529	510.01	*180	30	75	*200	30	120	*200	40	180
37	543	524.14	*180	30	75	*200	30	120	*200	40	180
38	557	538.27	*180	30	75	*200	30	120	*200	40	180
39	571	552.4	*180	30	75	*200	30	120	*200	40	180
40	585	566.54	*180	30	75	*200	30	120	*200	40	180



Sprockets for Roller Chains DIN8187-ISO/R606

1" 3/4 x 1" 1/4 mm

28A-1 -2 -3

CHAIN 配套链条尺寸: Pitch 节距: 44.45 mm
 Internal width 内链板宽度: 30.99 mm
 Roller dia. 滚径: 27.94 mm

SPROCKET 链轮尺寸: Tooth radius 齿半径 r: 44 mm
 Radius width 圆弧倒角宽度 C: 5 mm
 Tooth width 齿宽 h1: 29.4 mm
 Tooth width 齿宽 L: 28.8 mm
 Tooth width 齿宽 h2: 88.4 mm
 Tooth width 齿宽 h3: 148 mm
 Full height 总高 H:-

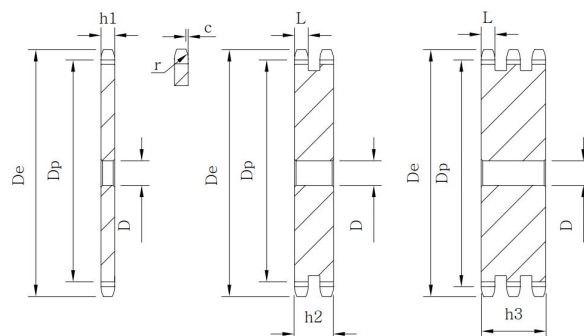

Teeth	齿数	De 外径	Dp 节径	Simplex 单排	Duplex 双排	Triplex 三排
				D 内孔	D 内孔	D 内孔
8		132	116.15	20	25	25
9		148.4	129.96	20	25	25
10		162.3	143.85	20	25	25
11		176.3	157.77	25	30	30
12		189.5	171.74	25	30	30
13		204.2	185.75	25	30	30
14		218.2	199.76	25	30	30
15		232.3	213.79	25	30	30
16		246.3	227.84	30	30	30
17		260.3	241.91	30	30	30
18		274	255.98	30	30	30
19		289	270.06	30	30	30
20		303	284.15	30	30	30
21		317	298.24	30	30	30
22		331	312.34	30	30	30
23		345	326.44	30	30	30
24		359	340.55	30	30	30
25		373	354.66	30	30	40
26		387	368.77	30	30	40
27		401.4	382.88	30	30	40
28		416	397	30	30	40
29		430	411.12	30	30	40
30		444	425.24	30	30	40
31		458	439.37	30	30	40
32		472	453.49	30	30	40
33		486	467.62	30	30	40
34		500	481.75	30	30	40
35		514	495.88	30	30	40
36		529	510.01	30	30	40
37		543	524.14	30	30	40
38		557	538.27	30	30	40
39		571	552.4	30	30	40
40		585	566.54	30	30	40



Sprockets for Roller Chains DIN8187-ISO/R606

2" x 1" 1/4 mm

32B-1 -2 -3

CHAIN 配套链条尺寸: Pitch 节距: 50.8 mm
 Internal width 内链板宽度: 30.99 mm
 Roller dia. 滚径: 29.21 mm

SPROCKET 链轮尺寸: Tooth radius 齿半径 r: 51 mm
 Radius width 圆弧倒角宽度 C: 6 mm
 Tooth width 齿宽 h1: 29.4mm
 Tooth width 齿宽 L: 28.8 mm
 Tooth width 齿宽 h2: 87.4 mm
 Tooth width 齿宽 h3: 146 mm
 Full height 总高 H:-

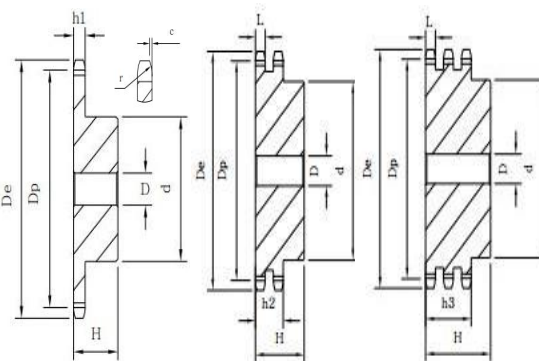

Material: C45 *Weld on hub

Teeth 齿数	De 外径	Dp 节径	Simplex 单排			Duplex 双排			Triplex 三排		
			d 搭径	D 内孔	H 总高	d 搭径	D 内孔	H 总高	d 搭径	D 内孔	H 总高
8	153.2	132.69	82	25	80	82	30	120	82	30	180
9	169	148.54	88	25	80	88	30	120	88	30	180
10	185	164.54	104	25	80	104	30	120	104	30	180
11	200.8	180.34	120	30	80	120	30	120	120	30	180
12	216.8	196.29	133	30	80	*133	30	120	*133	30	180
13	232.8	212.29	*145	30	80	*145	30	120	*145	30	180
14	248.8	228.29	*145	30	80	*145	30	120	*145	30	180
15	264.8	244.3	*145	30	80	*160	30	120	*160	30	180
16	280.9	260.4	*160	30	90	*160	30	120	*160	30	180
17	296.9	276.4	*160	30	90	*180	30	120	*180	30	180
18	313	292.55	*160	30	90	*180	30	120	*180	30	180
19	329.1	308.66	*160	30	90	*200	30	120	*200	30	180
20	345.2	324.71	*180	30	90	*200	30	120	*200	30	180
21	361.3	340.82	*180	30	90	*200	30	120	*200	40	180
22	377.5	356.98	*180	30	90	*200	30	120	*200	40	180
23	393.6	373.08	*180	30	90	*200	30	120	*200	40	180
24	409.7	389.18	*180	30	90	*200	30	120	*200	40	180
25	425.8	405.33	*180	30	90	*200	30	120	*200	40	180
26	441.9	421.44	*180	30	90	*200	30	120	*200	40	180
27	458.1	437.59	*180	30	90	*200	30	120	*200	40	180
28	474.2	453.69	*180	30	90	*200	30	120	*200	40	180
29	490.4	469.9	*180	30	90	*200	30	120	*200	40	180
30	506.5	486	*180	30	90	*200	30	120	*200	40	180
32	538.8	518.26	*180	30	90	*200	30	120	*200	40	180
35	589.5	566.72	*180	30	90	*200	30	120	*200	40	180
38	635.5	615.14	*180	30	90	*200	30	120	*200	40	180
40	670.3	647.49	*180	30	90	*200	30	120	*200	40	180
45	751	728.25	*180	30	90	*200	30	120	*200	40	180
50	831.8	809.04	*180	30	100	*200	30	120	*200	40	180
57	945	922.16	*180	30	100	*220	30	120	*200	40	180
60	993.4	970.65	*200	30	110	*220	30	120	*220	40	180
76	1252	1229.3	*200	30	110	*220	30	130	*238	40	180



Sprockets for Roller Chains DIN8187-ISO/R606

2" x 1" 1/4 mm

32A-1 -2 -3

CHAIN 配套链条尺寸: Pitch 节距: 50.8 mm
 Internal width 内链板宽度: 30.99 mm
 Roller dia. 滚径: 29.21 mm

SPROCKET 链轮尺寸: Tooth radius 齿半径 r: 51 mm
 Radius width 圆弧倒角宽度 C: 6 n
 Tooth width 齿宽 h1: 29.4 mm
 Tooth width 齿宽 L: 28.8 mm
 Tooth width 齿宽 h2: 87.4 mm
 Tooth width 齿宽 h3: 146 mm
 Full height 总高 H:-

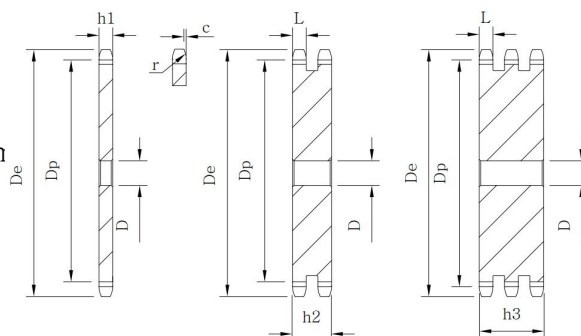

Teeth	齿数	De 外径	Dp 节径	Simplex 单排	Duplex 双排	Triplex 三排
				D 内孔	D 内孔	D 内孔
8		153.2	132.69	25	25	25
9		169	148.54	25	25	25
10		185	164.54	25	25	25
11		200.8	180.34	30	30	30
12		216.8	196.29	30	30	30
13		232.8	212.29	30	30	30
14		248.8	228.29	30	30	30
15		264.8	244.3	30	30	30
16		280.9	260.4	30	30	30
17		296.9	276.4	30	30	30
18		313	292.55	30	30	30
19		329.1	308.66	30	30	30
20		345.2	324.71	30	30	30
21		361.3	340.82	30	30	40
22		377.5	356.98	30	30	40
23		393.6	373.08	30	30	40
24		409.7	389.18	30	30	40
25		425.8	405.33	30	30	40
26		441.9	421.44	30	30	40
27		458.1	437.59	30	30	40
28		474.2	453.69	30	30	40
29		490.4	469.9	30	30	40
30		506.5	486	30	30	40
32		538.8	518.26	30	30	40
35		589.5	566.72	30	30	40
38		635.5	615.14	30	30	40
40		670.3	647.49	40	40	40
45		751	728.25	40	40	40
50		831.8	809.04	40	40	40
57		945	922.16	40	40	40
60		993.4	970.65	40	40	40
76		1252	1229.3	40	40	40



ASA Sprockets for Roller Chains DIN8188-ISO/R606

1/4" x 1/8" mm ASA 25B

CHAIN 配套链条尺寸: Pitch 节距: 6.35 mm
 Internal width 内链板宽度: 3.18 mm
 Roller dia. 滚径: 3.3 mm

SPROCKET 链轮尺寸: Tooth radius 齿半径 r: 6.4 mm
 Radius width 圆弧倒角宽度 C: 0.7 mm
 Tooth width 齿宽 h1: 2.9 mm
 Tooth width 齿宽 L: -
 Tooth width 齿宽 h2: -
 Tooth width 齿宽 h3: -
 Full height 总高 H:-

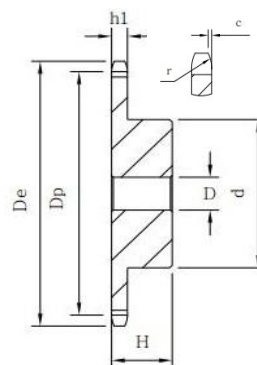

Teeth	齿数	De 外径	Dp 节径	Simplex 单排		
				d 搭径	D 内孔	H 总高
8		19.4	16.58	10	6	12
9		21.4	18.56	11.5	6	12
10		23.3	20.55	13	6	12
11		25.3	22.54	15	8	13
12		27.3	24.53	17	8	13
13		29.3	26.53	17	8	13
14		31.3	28.53	17	8	13
15		33.3	30.53	20	8	13
16		35.3	32.55	22	8	14
17		37.3	34.55	22	8	14
18		39.4	36.56	25	8	14
19		41.4	38.58	25	8	14
20		43.4	40.58	25	8	14
21		45.4	42.6	30	8	14
22		47.4	44.62	30	8	14
23		49.4	46.63	30	8	14
24		51.4	48.64	30	8	14
25		53.5	50.66	30	8	14
26		55.5	52.67	30	8	14
27		57.5	54.69	30	8	16
28		59.5	56.71	30	8	16
29		61.5	58.73	30	8	16
30		63.6	60.75	30	8	16
31		65.6	62.76	30	8	16
32		67.6	64.78	30	8	16
33		69.6	66.8	30	8	16
34		71.6	68.82	30	8	16
35		73.6	70.84	30	8	16
36		75.6	72.85	30	8	16
37		77.7	74.87	30	8	16
38		79.7	76.89	30	8	16
39		81.7	78.91	30	8	16
40		83.7	80.93	30	8	16



ASA Sprockets for Roller Chains DIN8188-ISO/R606

1/4" x 1/8" mm ASA 25A

CHAIN 配套链条尺寸: Pitch 节距: 6.35 mm
 Internal width 内链板宽度: 3.18 mm
 Roller dia. 滚径: 3.3 mm

SPROCKET 链轮尺寸: Tooth radius 齿半径 r: 6.4 mm
 Radius width 圆弧倒角宽度 C: 0.7 mm
 Tooth width 齿宽 h1: 2.9 mm
 Tooth width 齿宽 L: -
 Tooth width 齿宽 h2: -
 Tooth width 齿宽 h3: -
 Full height 总高 H:-

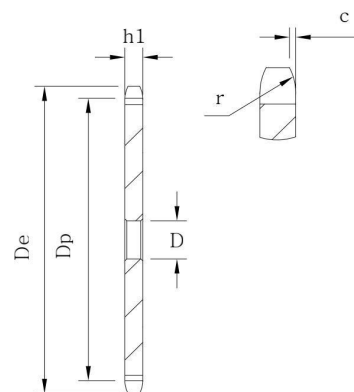

Teeth	齿数	De 外径	Dp 节径	Simplex 单排		
				D 内孔		
8		19.4	16.58	6		
9		21.4	18.56	6		
10		23.3	20.55	6		
11		25.3	22.54	8		
12		27.3	24.53	8		
13		29.3	26.53	8		
14		31.3	28.53	8		
15		33.3	30.53	8		
16		35.3	32.55	8		
17		37.3	34.55	8		
18		39.4	36.56	8		
19		41.4	38.58	8		
20		43.4	40.58	8		
21		45.4	42.6	8		
22		47.4	44.62	8		
23		49.4	46.63	8		
24		51.4	48.64	8		
25		53.5	50.66	8		
26		55.5	52.67	8		
27		57.5	54.69	8		
28		59.5	56.71	8		
29		61.5	58.73	8		
30		63.6	60.75	8		
31		65.6	62.76	10		
32		67.6	64.78	10		
33		69.6	66.8	10		
34		71.6	68.82	10		
35		73.6	70.84	10		
36		75.6	72.85	10		
37		77.7	74.87	10		
38		79.7	76.89	10		
39		81.7	78.91	10		
40		83.7	80.93	10		



ASA Sprockets for Roller Chains DIN8188-ISO/R606

3/8 x 3/16 mm

ASA 35B-1 -2

CHAIN 配套链条尺寸: Pitch 节距: 9.525 mm
 Internal width 内链板宽度: 4.77 mm
 Roller dia. 滚径: 5.08 mm

SPROCKET 链轮尺寸: Tooth radius 齿半径 r: 10 mm
 Radius width 圆弧倒角宽度 C: 1.2 mm
 Tooth width 齿宽 h1: 4.4 mm
 Tooth width 齿宽 L: 4.3 mm
 Tooth width 齿宽 h2: 14.4 mm
 Tooth width 齿宽 h3: 24.5 mm
 Full height 总高 H:-

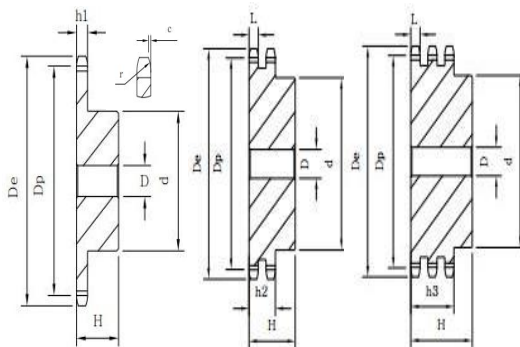

Teeth 齿数	De 外径	Dp 节径	Simplex 单排			Duplex 双排			Triplex 三排		
			d 搭径	D 内孔	H 总高	d 搭径	D 内孔	H 总高	d 搭径	D 内孔	H 总高
10	35.7	30.82	20	8	20						
11	38.69	33.8	22	8	25						
12	41.68	36.8	25	8	25						
13	44.68	39.8	28	8	25	28	10	25			
14	47.68	42.8	31	8	25	31	10	25			
15	50.69	45.81	34	8	25	34	10	25			
16	53.7	48.82	37	10	28	37	12	30			
17	56.72	51.83	38	10	28	40	12	30			
18	59.73	54.85	38	10	28	43	12	30			
19	62.75	57.87	45	10	28	46	12	30			
20	65.77	60.89	46	10	28	49	12	30			
21	68.79	63.91	46	10	28	52	12	30			
22	71.81	66.93	50	12	28	55	12	30			
23	74.83	69.95	52	12	28	58	12	30			
24	77.85	72.97	52	12	28	61	12	30			
25	80.88	76	57	12	28	64	12	30			
26	83.9	79.02	58	12	28	67	12	30			
27	86.93	82.04	58	12	28	70	12	30			
28	89.95	95.07	60	12	28	73	12	30			
30	96	91.12	60	12	28						



ASA Sprockets for Roller Chains DIN8188-ISO/R606

3/8 x 3/16 mm

ASA 35A-1 -2

CHAIN 配套链条尺寸: Pitch 节距: 9.525 mm
 Internal width 内链板宽度: 4.77 mm
 Roller dia. 滚径: 5.08 mm

SPROCKET 链轮尺寸: Tooth radius 齿半径 r: 10 mm
 Radius width 圆弧倒角宽度 C: 1.2 mm
 Tooth width 齿宽 h1: 4.4 mm
 Tooth width 齿宽 L: 4.3 mm
 Tooth width 齿宽 h2: 14.4 mm
 Tooth width 齿宽 h3: 24.5 mm
 Full height 总高 H:-

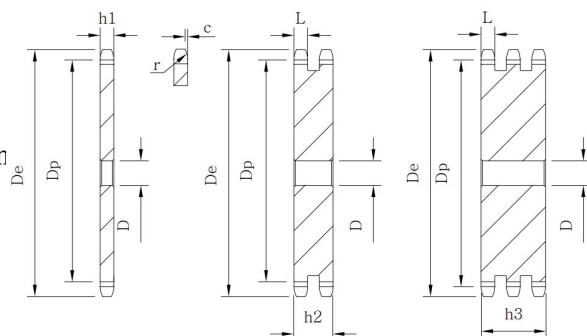

Teeth	齿数	De 外径	Dp 节径	Simplex 单排	Duplex 双排	Triplex 三排
				D 内孔	D 内孔	D 内孔
30		96	91.12		12	
32		102.06	97.17	12		
36		114.17	109.29	12		
38		120.22	115.34	12	14	
40		126.28	121.4	12		
45		141.43	136.55	16	16	
48		150.52	145.64	16		
57		177.79	172.91	16	16	
76		235.37	230.49	20	20	



ASA Sprockets for Roller Chains DIN8188-ISO/R606

1/2" x 5/16" mm

ASA 40B-1 -2 -3

CHAIN 配套链条尺寸: Pitch 节距: 12.7 mm
 Internal width 内链板宽度: 7.94 mm
 Roller dia. 滚径: 7.94 mm

SPROCKET 链轮尺寸: Tooth radius 齿半径 r: 13.5 mm
 Radius width 圆弧倒角宽度 C: 1.6 mm
 Tooth width 齿宽 h1: 7.4mm
 Tooth width 齿宽 L: 7.2mm
 Tooth width 齿宽 h2: 21.6mm
 Tooth width 齿宽 h3: 36 mm
 Full height 总高 H:-

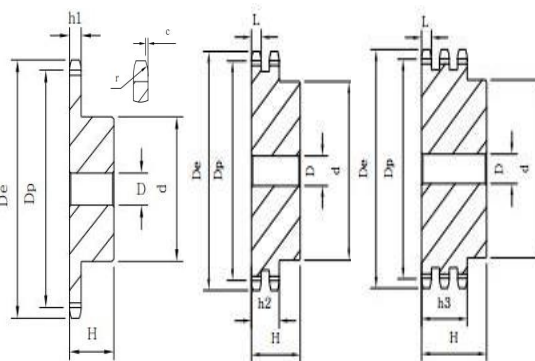

Teeth 齿数	De 外径	Dp 节径	Simplex 单排			Duplex 双排			Triplex 三排		
			d 搭径	D 内孔	H 总高	d 搭径	D 内孔	H 总高	d 搭径	D 内孔	H 总高
10	47.66	41.1	26	10	25						
11	51.64	45.08	29	10	25						
12	55.63	49.07	33	10	28				35	14	50
13	59.63	53.07	35	10	28	38	12	35	42	14	50
14	63.63	57.07	41	10	28	42	12	35	46	14	50
15	67.64	61.08	45	10	28	46	12	35	50	14	50
16	71.66	65.1	48	10	28	50	14	35	54	16	50
17	75.68	69.12	48	10	28	54	14	35	58	16	50
18	79.7	73.14	56	12	28	58	14	35	62	16	50
19	83.72	77.16	60	12	28	62	14	35	66	16	50
20	87.74	81.18	60	12	28	66	14	35	70	16	50
21	91.77	85.21	65	12	28	70	16	40	70	20	55
22	95.8	89.24	65	12	28	70	16	40	70	20	55
23	99.83	93.27	65	12	28	70	16	40	75	20	55
24	103.83	97.3	70	14	28	75	16	40	80	20	55
25	107.89	101.33	70	14	28	80	16	40	85	20	55
26	111.92	105.36	70	14	28	85	16	40	85	20	55
27	115.96	109.4	70	16	30	85	16	40	90	20	55
28	119.99	113.43	70	16	30	90	16	40	42	20	55
30	128.06	121.5	80	16	30	100	16	40			
32	136.13	129.57	80	16	30						
35	148.24	141.68	90	16	30						
36	152.28	145.72	90	16	30						
38	160.35	153.79	90	16	35						
40	168.43	161.87	90	16	35						



ASA Sprockets for Roller Chains DIN8188-ISO/R606

1/2" x 5/16" mm

ASA 40A-1 -2 -3

CHAIN 配套链条尺寸: Pitch 节距: 12.7 mm
 Internal width 内链板宽度: 7.94 mm
 Roller dia. 滚径: 7.94 mm

SPROCKET 链轮尺寸: Tooth radius 齿半径 r: 13.5 mm
 Radius width 圆弧倒角宽度 C: 1.6 mm
 Tooth width 齿宽 h1: 7.4 mm
 Tooth width 齿宽 L: 7.2 mm
 Tooth width 齿宽 h2: 21.6 mm
 Tooth width 齿宽 h3: 36 mm
 Full height 总高 H:-

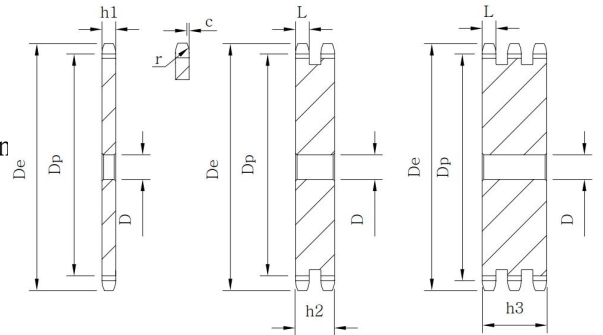

Teeth 齿数	De 外径	Dp 节径	Simplex 单排	Duplex 双排	Triplex 三排
			D 内孔	D 内孔	D 内孔
30	128.06	121.5			20
32	136.13	129.57		16	
38	160.35	153.79		20	25
40	168.43	161.87		20	
42	176.5	169.94	20		
45	188.62	182.06	20	20	25
48	200.74	194.18	20		
57	237.1	230.54	20	25	25
76	313.88	307.32	25	25	25
95	390.67	384.11		25	



ASA Sprockets for Roller Chains DIN8188-ISO/R606

5/8" x 3/8" mm

ASA 50B-1 -2 -3

CHAIN 配套链条尺寸: Pitch 节距: 15.875 mm
 Internal width 内链板宽度: 9.52 mm
 Roller dia. 滚径: 10.16 mm

SPROCKET 链轮尺寸: Tooth radius 齿半径 r: 17 mm
 Radius width 圆弧倒角宽度 C: 2 mm
 Tooth width 齿宽 h1: 9 mm
 Tooth width 齿宽 L: 8.8 mm
 Tooth width 齿宽 h2: 26.9 mm
 Tooth width 齿宽 h3: 45 mm
 Full height 总高 H:-

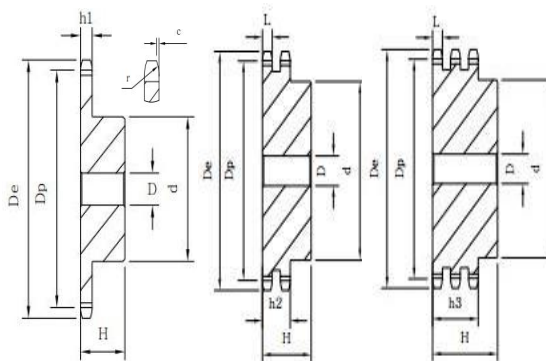

Teeth 齿数	De 外径	Dp 节径	Simplex 单排			Duplex 双排			Triplex 三排		
			d 搭径	D 内孔	H 总高	d 搭径	D 内孔	H 总高	d 搭径	D 内孔	H 总高
8	47	41.48	25	10	25						
9	52.6	46.42	30	10	25						
10	57.5	51.37	35	10	25						
11	63	56.34	37	12	30						
12	68	61.34	42	12	30				44	16	55
13	73	66.32	47	12	30	49	14	40	49	16	55
14	78	71.34	52	12	30	54	14	40	54	16	55
15	83	76.36	57	12	30	59	14	40	59	16	55
16	88	81.37	60	12	30	64	16	45	64	16	60
17	93	86.39	60	12	30	69	16	45	69	16	60
18	98.3	91.42	70	14	30	74	16	45	74	16	60
19	103.3	96.45	70	14	30	79	16	45	79	16	60
20	108.4	101.49	75	14	30	84	16	45	84	16	60
21	113.4	106.52	75	16	30	85	16	45	85	20	60
22	118	111.55	80	16	30	90	16	45	90	20	60
23	123.4	116.58	80	16	30	95	16	45	95	20	60
24	128.4	121.62	80	16	30	100	16	45	100	20	60
25	134	126.66	80	16	30	105	16	45	105	20	60
26	139	131.7	85	20	35				110	20	60
27	144	136.75	85	20	35				110	20	60
28	148.7	141.78	90	20	35				115	20	60
29	153.8	146.83	90	20	35						
30	158.8	151.87	90	20	35						
31	163.9	156.92	95	20	35						
32	168.9	161.95	95	20	35						
33	174.5	167	95	20	35						
34	179	172.05	95	20	35						
35	184.1	177.01	95	20	35						
36	189.1	182.15	100	20	35						
37	194.2	187.2	100	20	35						
38	199.2	192.24	100	20	35						
39	204.2	197.29	100	20	35						
40	209.3	202.34	100	20	35						



ASA Sprockets for Roller Chains DIN8188-ISO/R606

5/8" x 3/8" mm ASA 50A-1 -2 -3

CHAIN 配套链条尺寸: Pitch 节距: 15.875 mm
 Internal width 内链板宽度: 9.52 mm
 Roller dia. 滚径: 10.16 mm

SPROCKET 链轮尺寸: Tooth radius 齿半径 r: 17 mm
 Radius width 圆弧倒角宽度 C: 2 mm
 Tooth width 齿宽 h1: 9 mm
 Tooth width 齿宽 L: 8.8 mm
 Tooth width 齿宽 h2: 26.9 mm
 Tooth width 齿宽 h3: 45 mm
 Full height 总高 H:-

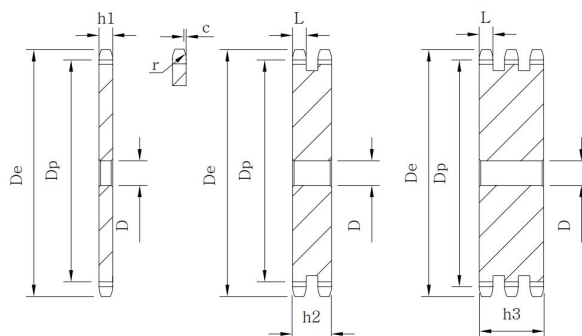

Teeth	齿数	De 外径	Dp 节径	Simplex 单排	Duplex 双排	Triplex 三排
				D 内孔	D 内孔	D 内孔
8		47	41.48	10		
9		52.6	46.42	10		
10		57.5	51.37	10		
11		63	56.34	10		
12		68	61.34	10		
13		73	66.32	10		
14		78	71.34	10		
15		83	76.36	10		
16		88	81.37	12		
17		93	86.39	12		
18		98.3	91.42	12		
19		103.3	96.45	12		
20		108.4	101.49	12		
21		113.4	106.52	12		
22		118	111.55	12		
23		123.4	116.58	12		
24		128.4	121.62	12		
25		134	126.66	12		
26		139	131.7	16		
27		144	136.75	16		
28		148.7	141.78	16		
29		153.8	146.83	16		
30		158.8	151.87	16	20	20
31		163.9	156.92	16		
32		168.9	161.95	16		
33		174.5	167	16		
34		179	172.05	16		
35		184.1	177.01	16		
36		189.1	182.15	20		
37		194.2	187.2	20		
38		199.2	192.24	20	20	25
39		204.2	197.29	20		
40		209.3	202.34	20		



ASA Sprockets for Roller Chains DIN8188-ISO/R606

3/4" x 1/2" mm

ASA 60B-1 -2 -3

CHAIN 配套链条尺寸: Pitch 节距: 19.05 mm
 Internal width 内链板宽度: 12.7 mm
 Roller dia. 滚径: 11.91 mm

SPROCKET 链轮尺寸: Tooth radius 齿半径 r: 20 mm
 Radius width 圆弧倒角宽度 C: 2.4 mm
 Tooth width 齿宽 h1: 12 mm
 Tooth width 齿宽 L: 11.8 mm
 Tooth width 齿宽 h2: 34.6 mm
 Tooth width 齿宽 h3: 57.4 mm
 Full height 总高 H:-

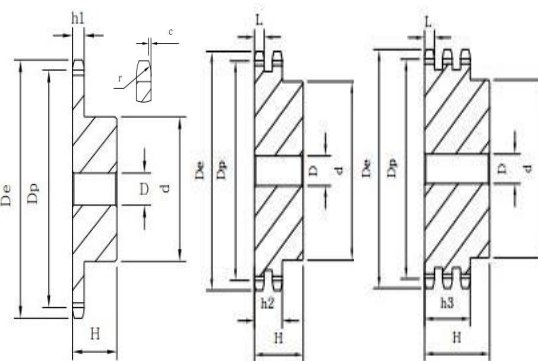

Teeth 齿数	De 外径	Dp 节径	Simplex 单排			Duplex 双排			Triplex 三排		
			d 搭径	D 内孔	H 总高	d 搭径	D 内孔	H 总高	d 搭径	D 内孔	H 总高
10	71.54	61.64	42	12	30	42	12	45			
11	77.51	67.61	45	12	30	47	16	50			
12	83.49	73.61	45	12	30	53	16	50	53	20	70
13	89.49	79.59	58	14	35	59	16	50	59	20	70
14	95.5	85.61	60	14	35	65	16	50	65	20	70
15	101.52	91.63	60	14	35	71	16	50	71	20	70
16	107.54	97.65	75	16	35	77	20	50	77	20	70
17	113.56	103.67	75	16	35	83	20	50	83	20	70
18	119.59	109.71	75	16	35	89	20	50	89	20	70
19	125.63	115.75	80	16	35	95	20	50	95	20	70
20	131.67	121.78	80	16	35	100	20	50	100	20	70
21	137.71	127.82	80	16	35	100	20	50	100	20	70
22	143.75	133.86	90	20	40	100	20	50	100	20	70
23	149.79	139.9	90	20	40	110	20	50	110	20	70
24	155.84	145.94	90	20	40	110	20	50	110	20	70
25	161.88	152	90	20	40	120	20	50	120	20	70
26	167.93	158.04	90	20	40	120	20	50			
27	173.98	164.09	90	20	40	120	20	50			
28	183.03	170.13	95	20	40	120	20	50			
30	192.14	182.25	95	20	40	120	20	50			



ASA Sprockets for Roller Chains DIN8188-ISO/R606

3/4" x 1/2" mm

ASA 60A-1 -2 -3

CHAIN 配套链条尺寸: Pitch 节距: 19.05 mm
 Internal width 内链板宽度: 12.7 mm
 Roller dia. 滚径: 11.91 mm

SPROCKET 链轮尺寸: Tooth radius 齿半径 r: 20 mm
 Radius width 圆弧倒角宽度 C: 2.4 mm
 Tooth width 齿宽 h1: 12 mm
 Tooth width 齿宽 L: 11.8 mm
 Tooth width 齿宽 h2: 34.6 mm
 Tooth width 齿宽 h3: 57.4 mm
 Full height 总高 H:-

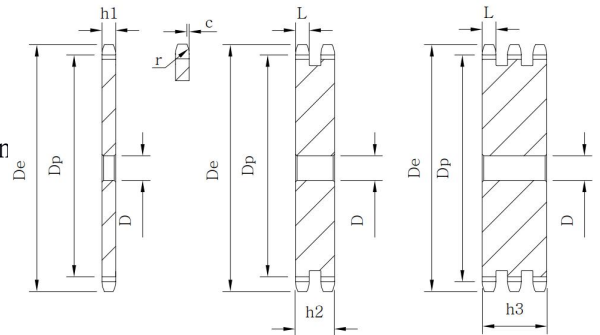

Teeth	齿数	De 外径	Dp 节径	Simplex 单排	Duplex 双排	Triplex 三排
				D 内孔	D 内孔	D 内孔
30		192.14	182.25			20
32		204.24	194.35		20	
38		240.58	230.69	20	25	25
40		252.69	242.8	20	25	
45		282.98	273.09	25	25	25
48		301.16	291.27	25		
57		355.7	345.81	25	25	30
76		470.87	460.98	30	30	30
95		586.06	576.17		30	



ASA Sprockets for Roller Chains DIN8188-ISO/R606

1" x 5/8" mm

ASA 80B-1 -2 -3

CHAIN 配套链条尺寸: Pitch 节距: 25.4 mm
 Internal width 内链板宽度: 15.88 mm
 Roller dia. 滚径: 15.88 mm

SPROCKET 链轮尺寸: Tooth radius 齿半径 r: 27 mm
 Radius width 圆弧倒角宽度 C: 3.2 mm
 Tooth width 齿宽 h1: 15 mm
 Tooth width 齿宽 L: 14.7 mm
 Tooth width 齿宽 h2: 44 mm
 Tooth width 齿宽 h3: 73.3 mm
 Full height 总高 H:-

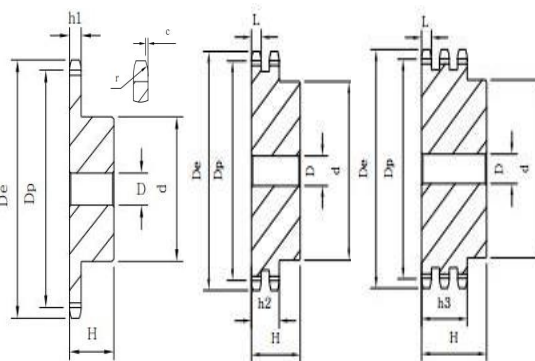

Teeth 齿数	D _e 外径	D _p 节径	Simplex 单排			Duplex 双排			Triplex 三排		
			d 搭径	D 内孔	H 总高	d 搭径	D 内孔	H 总高	d 搭径	D 内孔	H 总高
8	79.49	66.37	42	16	35						
9	87.38	74.27	50	16	35						
10	95.32	82.19	55	16	35						
11	103.28	90.14	61	16	40						
12	111.26	98.14	69	16	40	72	20	70	72	25	100
13	119.26	106.12	78	16	40	78	20	70	78	25	100
14	127.27	114.15	84	16	40	86	20	70	86	25	100
15	135.29	122.17	92	16	40	94	20	70	94	25	100
16	143.32	130.2	100	20	45	102	20	70	102	30	100
17	151.35	138.22	100	20	45	110	20	70	110	30	100
18	159.39	148.28	100	20	45	118	20	70	118	30	100
19	167.44	154.33	100	20	45	126	20	70	126	30	100
20	175.49	162.38	100	20	45	130	20	70	130	30	100
21	183.54	170.43	110	20	50	130	25	70			
22	191.6	178.48	110	20	50						
23	199.66	186.53	110	20	50						
24	207.72	194.59	110	20	50						
25	215.78	202.66	110	20	50						
26	223.84	210.72	120	20	50						
27	231.91	218.79	120	20	50						
28	239.98	226.85	120	20	50						
29	248.05	234.92	120	20	50						
30	256.12	243	120	20	50						



ASA Sprockets for Roller Chains DIN8188-ISO/R606

1" x 5/8" mm

ASA 80A-1 -2 -3

CHAIN 配套链条尺寸: Pitch 节距: 25.4 mm
 Internal width 内链板宽度: 15.88 mm
 Roller dia. 滚径: 15.88 mm

SPROCKET 链轮尺寸: Tooth radius 齿半径 r: 27 mm
 Radius width 圆弧倒角宽度 C: 3.2 mm
 Tooth width 齿宽 h1: 15 mm
 Tooth width 齿宽 L: 14.7 mm
 Tooth width 齿宽 h2: 44 mm
 Tooth width 齿宽 h3: 73.3 mm
 Full height 总高 H:-

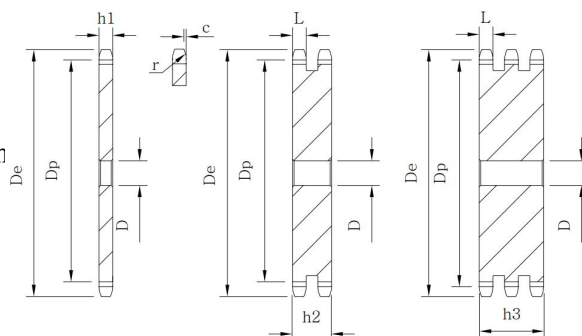

Teeth	齿数	De 外径	Dp 节径	Simplex 单排	Duplex 双排	Triplex 三排
				D 内孔	D 内孔	D 内孔
8		79.49	66.37	15		
9		87.38	74.27	15		
10		95.32	82.19	15		
11		103.28	90.14	15		
12		111.26	98.14	15		
13		119.26	106.12	15		
14		127.27	114.15	15		
15		135.29	122.17	15		
16		143.32	130.2	19		
17		151.35	138.22	19		
18		159.39	148.28	19		
19		167.44	154.33	19		
20		175.49	162.38	19		
21		183.54	170.43	20		
22		191.6	178.48	20		
23		199.66	186.53	20		
24		207.72	194.59	20		
25		215.78	202.66	20	25	30
26		223.84	210.72	20		
27		231.91	218.79	20		
28		239.98	226.85	20		
29		248.05	234.92	20		
30		256.12	243	20	35	30
32		272.26	259.13	25		
35		296.48	283.36	25		
38		320.7	307.59	25	25	30
45		377.24	364.12	25	25	30
50		417.64	404.52	25		
57		474.2	461.08	25	25	40
76		627.8	614.64	25	25	40



ASA Sprockets for Roller Chains DIN8188-ISO/R606

1" 1/4 x 3/4" mm

ASA 100B-1 -2

CHAIN 配套链条尺寸: Pitch 节距: 31.75 mm
 Internal width 内链板宽度: 19.05 mm
 Roller dia. 滚径: 19.05 mm

SPROCKET 链轮尺寸: Tooth radius 齿半径 r: 33.5 mm
 Radius width 圆弧倒角宽度 C: 4 mm
 Tooth width 齿宽 h1: 18 mm
 Tooth width 齿宽 L: 17.7 mm
 Tooth width 齿宽 h2: 53.5 mm
 Tooth width 齿宽 h3: 89.2 mm
 Full height 总高 H:-

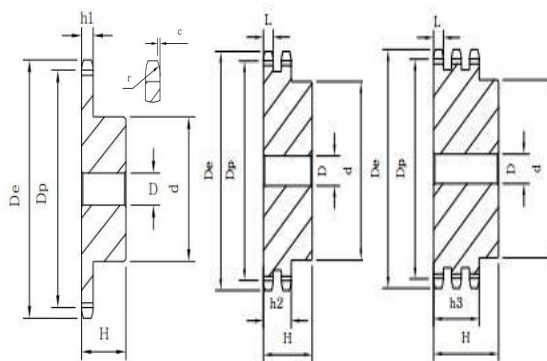

Teeth 齿数	De 外径	Dp 节径	Simplex 单排			Duplex 双排			Triplex 三排		
			d 搭径	D 内孔	H 总高	d 搭径	D 内孔	H 总高	d 搭径	D 内孔	H 总高
8	98.1	82.96	53	20	40						
9	108	92.84	63	20	40						
10	117.9	102.74	70	20	40						
11	127.8	112.68	77	20	45						
12	137.8	122.68	88	20	45	90	20	80			
13	147.8	132.65	98	20	45	100	20	80			
14	157.8	142.68	108	20	45	110	20	80			
15	167.9	152.72	118	20	45	120	20	80			
16	177.9	162.75	120	25	50	120	25	80			
17	187.9	172.78	120	25	50	120	25	80			
18	198	182.85	120	25	50						
19	208.1	192.91	120	25	50						
20	218.1	202.98	120	25	50						
21	228.2	213.04	140	25	55						
22	238.3	223.11	140	25	55						
23	248.3	233.17	140	25	55						
24	258.4	243.23	140	25	55						
25	268.5	253.33	140	25	55						



ASA Sprockets for Roller Chains DIN8188-ISO/R606

1" 1/4 x 3/4" mm ASA 100A-1 -2

CHAIN 配套链条尺寸: Pitch 节距: 31.75 mm
 Internal width 内链板宽度: 19.05 mm
 Roller dia. 滚径: 19.05 mm

SPROCKET 链轮尺寸: Tooth radius 齿半径 r: 33.5 mm
 Radius width 圆弧倒角宽度 C: 4 mm
 Tooth width 齿宽 h1: 18 mm
 Tooth width 齿宽 L: 17.7 mm
 Tooth width 齿宽 h2: 53.5 mm
 Tooth width 齿宽 h3: 89.2 mm
 Full height 总高 H:-

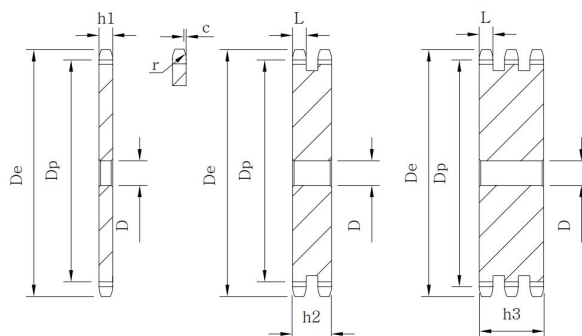

Teeth	齿数	De 外径	Dp 节径	Simplex 单排	Duplex 双排	Triplex 三排
				D 内孔	D 内孔	D 内孔
8		98.1	82.96	16		
9		108	92.84	16		
10		117.9	102.74	16		
11		127.8	112.68	16		
12		137.8	122.68	20		
13		147.8	132.65	20		
14		157.8	142.68	20		
15		167.9	152.72	20		
16		177.9	162.75	20		
17		187.9	172.78	20		
18		198	182.85	20		
19		208.1	192.91	20		
20		218.1	202.98	20	25	
21		228.2	213.04	25		
22		238.3	223.11	25		
23		248.3	233.17	25		
24		258.4	243.23	25		
25		268.5	253.33	25	25	
26		278.6	263.4	25		
27		288.6	273.4	25		
28		298.7	283.56	25		
29		308.8	293.65	25		
30		318.9	303.75	25	25	
321		329	313.85	25		
32		339.1	323.91	25		
33		349.2	334.01	25		
34		359.3	344.1	25		
35		369.4	354.2	25		
36		379.5	364.3	25		
37		389.5	374.39	25		
38		399.6	384.49	25	30	
39		409.7	394.59	25		
40		419.8	404.68	25		



ASA Sprockets for Roller Chains DIN8188-ISO/R606

1" 1/2 x 1" mm

ASA 120B-1 -2

CHAIN 配套链条尺寸: Pitch 节距: 38.1 mm
 Internal width 内链板宽度: 25.4 mm
 Roller dia. 滚径: 22.22 mm

SPROCKET 链轮尺寸: Tooth radius 齿半径 r: 40.5 mm
 Radius width 圆弧倒角宽度 C: 4.8 mm
 Tooth width 齿宽 h1: 24.1 mm
 Tooth width 齿宽 L: 23.6 mm
 Tooth width 齿宽 h2: 69 mm
 Tooth width 齿宽 h3: 114.5 mm
 Full height 总高 H:-

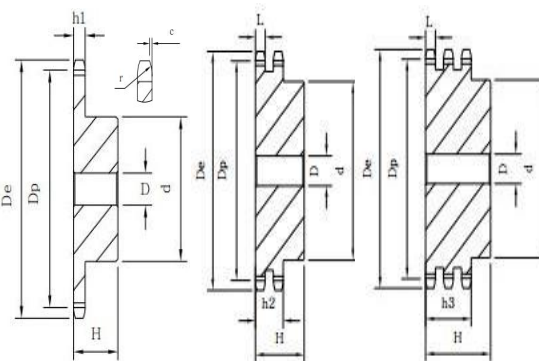

Teeth 齿数	De 外径	Dp 节径	Simplex 单排			Duplex 双排			Triplex 三排		
			d 搭径	D 内孔	H 总高	d 搭径	D 内孔	H 总高	d 搭径	D 内孔	H 总高
8	119.04	99.55	58	20	45						
9	130.88	111.4	70	20	45						
10	142.77	123.29	80	20	45						
11	154.71	135.21	90	25	50						
12	166.69	147.22	102	25	50	102	25	100			
13	178.68	159.18	114	25	50	114	25	100			
14	190.7	171.22	128	25	50	128	25	100			
15	202.73	183.26	140	25	50	140	25	100			



ASA Sprockets for Roller Chains DIN8188-ISO/R606

1" 1/2 x 1" mm

ASA 120A-1 -2

CHAIN 配套链条尺寸: Pitch 节距: 38.1 mm
 Internal width 内链板宽度: 25.4 mm
 Roller dia. 滚径: 22.22 mm

SPROCKET 链轮尺寸: Tooth radius 齿半径 r: 40.5 mm
 Radius width 圆弧倒角宽度 C: 4.8 mm
 Tooth width 齿宽 h1: 24.1 mm
 Tooth width 齿宽 L: 23.6 mm
 Tooth width 齿宽 h2: 69 mm
 Tooth width 齿宽 h3: 114.5 mm
 Full height 总高 H:-

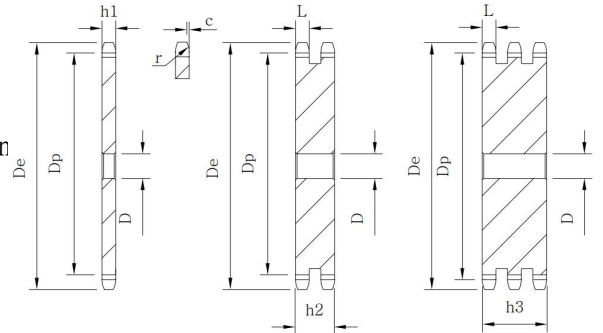

Teeth	齿数	De 外径	Dp 节径	Simplex 单排	Duplex 双排	Triplex 三排
				D 内孔	D 内孔	D 内孔
16		214.77	195.29	25		
17		226.83	207.35	25	25	
18		238.89	219.41	25	25	
20		263.03	243.55	25	25	
22		287.2	267.72	25		
25		323.47	303.99	25	25	
30		383.97	364.49	30	30	
32		408.19	388.71	30		
38		480.85	461.37	30	30	
45		565.67	546.19	30	40	
57		711.1	691.62		40	

